

DOCUMENT RESUME

ED 101 791

95

JC 750 145

**AUTHOR** Stinchcomb, C. Larry  
**TITLE** Decision Time--1973: Will Maine Broaden the Base of Higher Education through Community Colleges? A Report to the State of Maine Higher Education Facilities Commission.  
**INSTITUTION** Maine State Higher Education Facilities Commission, Augusta.  
**SPONS AGENCY** Bureau of Higher Education (DHEW/OE), Washington, D.C. Div. of Academic Facilities.  
**PUB DATE** 73  
**NOTE** 132p.  
**EDRS PRICE** MF-\$0.76 HC-\$6.97 PLUS POSTAGE  
**DESCRIPTORS** \*Community Attitudes; Community Benefits; Community Characteristics; Community Study; Construction Needs; Educational History; \*Educational Needs; \*Educational Planning; \*Facility Planning; Facility Requirements; \*Junior Colleges; Labor Conditions; Manpower Needs; Student Attitudes  
**IDENTIFIERS** \*Maine

**ABSTRACT**

This study was commissioned to provide data related to program and facility needs of the community college proposed in the Lewiston-Auburn area. A brief history of the two-year college movement in general, and in Maine in particular, is followed by descriptions of three area surveys. The High School Survey of 2,246 junior and senior year students at seven local high schools found that 45 percent of the 1,486 students intending to continue education beyond high school would prefer to attend a low-cost local two-year college if one were available. Thirty-nine percent of the 662 students not intending to continue beyond high school indicated they would change their minds about continuing their schooling if a low-cost local community college were available. The Industrial Survey of 23 local businesses and industries found that approximately 10 percent of those presently employed needed their skills upgraded and that between 1972 and 1975 an additional 4,356 employees will be needed to fill anticipated vacancies and new positions. The Model Cities Survey found that higher wages and more jobs were the most important factors needed to improve area living conditions. Community suggestions and present area educational opportunities were recorded, and a report of existing and needed facilities, along with a report of potential building costs, is included. (DC)

BEST COPY AVAILABLE

# DECISION TIME -- 1973

## *Will Maine Broaden the Base of Higher Education through Community Colleges?*

JC 750 145 ED101791

*Equal higher  
educational opportunity*

*Low cost*

*Open door policy*

*Geographic  
Accessibility*

*Unique course  
offerings*

*Community-based*

LEWISTON AND AUBURN  
SPECIAL OPPORTUNITY  
FACILITIES PLANNING  
PROJECT

**A Report  
to the  
State of Maine  
Higher Education Facilities Commission**

**Director:  
C. Larry Stinchcomb, Ph.D.  
University of Maine at Farmington**

This project was supported in whole by a Comprehensive Planning Grant awarded under Title 1 of the Higher Education Facilities Act, as amended, from the Division of Academic Facilities of the U. S. Office of Education.

## **ACKNOWLEDGMENTS**

The director of this report wishes to acknowledge the aid and encouragement of Dr. Einar Olsen, President of the University of Maine at Farmington, and Mr. Wayne Ross, Director of Maine's Higher Education Facilities Commission. Recognition should also be given to the chief consultants of the project, Dr. Carrel Anderson and Dr. Harvey Morley for their diligent efforts. Finally, appreciation is expressed to the advisory council for their group endurance and individual assistance.

### **Chief Consultants:**

**Anderson, Carrel M. Ph.D.**  
**Director of International Programs**  
**Associate Professor Educational**  
**Administration and Higher Education**  
**College of Education**  
**The University of Alabama**

**Morley, Harvey Ed.D.**  
**Planning Director**  
**Florida Junior College**  
**Jacksonville, Florida**

## **MAINE HIGHER EDUCATION FACILITIES COMMISSION\***

**Carroll R. McGary**  
**Commissioner of Educational and Cultural Services**

**Wayne H. Ross**  
**Executive Director**

**Mr. Christo Anton**  
**6 Cherry Lane**  
**Biddeford, Maine 04005**

**Dana R. Darling**  
**2 Lights Road**  
**Cape Elizabeth, Maine 04107**

**Mr. John Ezhaya**  
**Upper Main Street**  
**Norridgewock, Maine 04957**

**Mrs. John R. Foster (Inge)**  
**Dresden**  
**Maine 04342**

**Mrs. Jon Lund (Sylvia)**  
**65 Stone Street**  
**Augusta, Maine 04330**

**Mr. Robert W. Marquis**  
**Violette Street**  
**Van Buren, Maine 04785**

**Mrs. Marc A. Nault (Julia)**  
**Kennebec Road**  
**Machias, Maine 04654**

**Mrs. James Sheppard (Lucille)**  
**133 Duck Pond Road**  
**Westbrook, Maine 04092**

**\* same as State Board of Education**

## TABLE OF CONTENTS

	<b>Page</b>
<b>ACKNOWLEDGEMENTS</b>	iii
<b>MAINE HIGHER EDUCATION FACILITIES COMMISSION</b>	iv
<b>LIST OF TABLES</b>	vi
<b>LIST OF ILLUSTRATIONS</b>	viii
<b>INTRODUCTION</b>	ix
<b>I. AIM OF THE PROJECT</b>	<b>1</b>
A. Statement of the Project Aim	1
B. Statement of Objectives	2
C. The Objectives Expanded	2
<b>II. PROCEDURES</b>	<b>3</b>
A. Conceptual Planning Model	3
B. Advisory Council	3
C. Review of Literature	5
D. Assessment	6
E. Analysis	6
<b>III. BACKGROUND</b>	<b>7</b>
A. State Reports Leading to Lewiston-Auburn Planning Project	7
B. State Reports Completed During the Project	9
<b>IV. PHILOSOPHY AND FUNCTION OF THE COMMUNITY COLLEGE</b>	<b>13</b>
<b>V. POST-SECONDARY EDUCATIONAL NEEDS IN THE LEWISTON - AUBURN AREA</b>	<b>37</b>
A. High School Survey	37
B. The Industrial Survey	48
C. The Model Cities Survey	50
D. Post-secondary Opportunities in the Lewiston-Auburn Area	54
E. Input From Community Sources	62
F. Facilities Report	68
<b>VI. ALTERNATIVES FOR ACTION</b>	<b>73</b>
<b>BIBLIOGRAPHY</b>	<b>77</b>
<b>APPENDICES</b>	<b>79</b>

## LIST OF TABLES

<b>Table</b>	<b>Page</b>
1. Public Post-Secondary Education Institutions in Maine: Actual (1968) and Projected (1977) Enrollments	9
2. Community College Enrollments — FTE	11
3. United States Projected Population by Age Groups for 1970 and 1980	20
4. Community College Projections for 1970 and 1980 Based Upon Various Numbers per 1000 Total Population	21
5. Educational Level of Parents	38
6. Language Spoken Most Often at Home	39
7. Children per Family	39
8. Favorite High School Subject	39
9. Career Choice	40
10. Parental View of Post-Secondary Education	40
11. Intention of Students to Continue Education Beyond High School	41
12. Type of Institution Planning to Attend	41
13. Prefer to Attend a Two-Year, Low Cost Community College if Available	41
14. Plans to Finance Post-Secondary Education	42
15. Reasons for not Planning to Continue Education	42
16. Influence on Non-College Bound Students of Availability of a Low Cost, Local Community College	43
17. Influence on Non-College Bound Students of Financial Aid and Local Community College	43
18. Estimate of Academic Rank in Class	43
19. Student Selection Between Two- and Four- year Programs	44
20. Student Selection of Two-Year Programs Ranked by Degree of Interest	44
21. Program Categories Ranked by Popularity Among Students	45
22. Student Selection of Specific Subject Areas Ranked by Degree of Interest	45
23. Selected Characteristics of Students Enrolled in Three Curriculums in 63 Comprehensive Community Colleges, in Percentages	47
24. Selected Job Categories — Skill Upgrading and Projected Openings by 1975	48



<b>Table</b>	<b>Page</b>
25. Selected Job Categories — Skill Upgrading and Projected Openings by 1975 (adjusted)	49
26. Jobs Other Than "Working Men's Jobs" Held by Model Cities Males	50
27. Skill Level of Working Males in Model Cities	50
28. Attitude Toward Job of Employed Persons in Model Cities	51
29. Factors Needed to Improve Living Conditions in Model Cities	51
30. Salaries of Model Cities Principal Wage Earners	51
31. Recreation of Residents of Model Cities — Adults	52
32. Recreation of Residents of Model Cities — Youths	52
33. Degree of Satisfaction with Recreation Provided in Model Cities	52
34. Residents of Model Cities Reared in Bilingual Homes	52
35. Model Cities Students Attending College in Lewiston	53
36. Model Cities High School Students Planning to Attend College	53
37. Model Cities Workers Desiring Additional Training	53
38. Type of Job Training Desired	53
39. Student Population Characteristics of Lewiston-Auburn Post- Secondary Institutions	56

## LIST OF ILLUSTRATIONS

<b>Figure</b>		<b>Page</b>
1.	Comprehensive Community College Curriculum Facilities Planning Model	4
2.	Changes in Distribution of Total Enrollment in Higher Education, by Type of Institution, Actual, 1963 and 1970, and Projected, 1980 to 2000	16
3.	Enrollment in Two-Year Colleges, United States, 1930-1970	23
4.	Characteristics of Students in Two-Year Colleges	23
5.	Percentage of Undergraduates Enrolled in Two-Year Institutions of Higher Education, by State, 1968 (Map)	24
6.	Organization Chart of Public Higher Education Institutions in Maine	34
7.	Consolidated Course Matrix	58

## INTRODUCTION

Certainly, one of the most exciting movements in American education today is that of the comprehensive community college. Indeed, comprehensive community colleges have been at the cutting edge of meaningful change in post secondary education for more than a decade.

Community colleges have sprung up across the nation during recent years at an unbelievable rate of an average of one a week. This is an indication of the legitimacy of the basic approach of these institutions to education -- to be responsive to the real educational needs and interests of people of all ages, and to provide for the widest possible constituency an equal opportunity for a quality post high school education."

The state of Maine has been aware of the need for comprehensive community colleges for several years. Steps have been taken to plan and develop a system of community colleges which would serve the growing educational needs of citizens in every area of the state. Previous statewide studies revealed that top priority should be given the establishment of community colleges in the Lewiston Auburn and York areas.

This study was commissioned to provide data related to program and facility needs of the institution proposed for the Lewiston-Auburn area. The report is respectfully submitted to the State of Maine Higher Education Planning Commission for consideration and utilization as a component of the master plan for higher education in the state.

# I. AIM OF THE PROJECT

## I. AIM OF THE PROJECT

A convergence of several situations stimulated the development of this proposal and grant request. First, the University of Maine growth and development plans have as a top priority the establishment of a community college in the Lewiston-Auburn area. This decision was reached following the Chancellor's comprehensive study in 1969. The study was conducted by the Higher Education Planning Commission under the Chairmanship of Judge Frank Coffin. Second, an existing private junior college in Lewiston, Bliss College, has reached a virtual financial crisis which resulted in its operation being almost terminated in 1969. In 1971, the Bliss College Board of Trustees formally declared a desire to explore the feasibility of becoming a part of the state university system. Third, leaders in the Model Cities area of Lewiston, in which the Bliss College facilities are located, are searching for avenues through which the education, job skills, and general cultural background of many of the area's residents may be improved and upgraded.

### A. Statement of the Project Aim

A basic task of the project as presented in the proposal and grant request was to provide information whereby an equitable decision might be made regarding the possible role of Bliss College in the state's efforts to provide needed educational services to residents of the Model Cities area. In addition to complying with this stated purpose, it was determined that this project should serve a need brought into focus by the statewide report, **Special Opportunity Facilities Planning Project**, directed by Dr. Stanley L. Freeman, Jr. That need surfaced in the Freeman report as follows:

If the community college concept with its one- and two-year programs is to be available to as many people in the State as possible, it is suggested that consideration be given to locations in which the population base will support such an effort and where commuting distance to existing institutions which offer such programs is beyond a reasonable distance (40 miles is suggested). Based on population, new facilities should be considered for less-than-baccalaureate programs in the York County area and the Lewiston-Auburn industrial complex area.

The statement of aim of the project was designed to establish a working base broad enough to generate a study which could be utilized by the Higher Education Planning Commission in the continuing community college planning process. The statement was finalized as follows:

To determine through appropriate and responsible means the

precise type and scope of a responsive post-secondary institution needed in the Lewiston-Auburn area.

## **B. Statement of Objectives**

First objective: To design post-secondary education programs which are addressed to the needs of residents in the Model Cities area. Specifically, the programs will include (1) collegiate level two-year transfer and terminal degree programs, (2) non-degree retraining programs for the upgrading of skills, (3) adult education programs regardless of degree status, and (4) those programs and activities whose purpose is to upgrade the general cultural atmosphere of the area.

Second objective: To develop recommendations and alternatives regarding the physical facilities required to accommodate the post-secondary education programs designed for the area.

Third objective: To explore the possibilities of the establishment of an appropriate working relationship between Bliss College and the University of Maine for the purpose of providing needed educational and training services in the Model Cities area.

## **C. The Objectives Expanded**

The above objectives were set forth in the proposal and grant request. However, the nature of the project as viewed in the context of higher education planning in Maine required that the objective be expanded to encompass, in addition to the needs of citizens in the Model Cities area, the needs of citizens throughout the Lewiston-Auburn area. Indeed, the proposal and grant request state: "If such a college is established, it will be primarily concerned with covering the needs of post-secondary students within a radius of approximately twenty to thirty miles of the Lewiston-Auburn area. The needs of the Model Cities area will be one of the concerns of this community college in its development of programs."

## II. PROCEDURES

The procedures employed in this study focused upon the systematic collection and analysis of pertinent data. To expedite the work of conceptual planning model, Figure 1, was developed. Additional important steps included establishing an advisory council, reviewing the community college literature, reviewing the higher education planning reports produced in Maine since 1965, assessing the post-secondary educational opportunities in the Lewiston-Auburn area, assessing the post-secondary educational needs in the area, as viewed by high school students, industries, Model Cities residents, and others, analyzing, and synthesizing the data. A flow chart which outlined the planned procedures is included as Appendix A.

### A. Conceptual Planning Model

Basically, the model was intended to represent the various components of the study, to illustrate the interactions and relationships, of the components, and to indicate the activity flow from data collection to data utilization. A comprehensive community college is a service institution. It must be designed to serve the needs of the citizens who live in the area in which it is located. Then, the very nature of the study required collecting data from appropriate sources and utilizing them properly. The model should illustrate this.

### B. Advisory Council

Higher education in Maine traditionally has been thought of in terms of something for the elite. The low percentage of high school graduates who enter any form of higher education may be an indication of this attitude. Nothing explodes the elitism myth as does the presence of a community college which strives to meet the needs of all the people within its area of service.

The Advisory Council was established in Lewiston-Auburn to serve as a vehicle through which the many voices in the community may have input into the study at the director's level. The composition of the Council was:

1. four residents of the Model Cities area
2. the education officer of the Model Cities area
3. one representative of the Bliss College Board of Trustees
4. one University of Maine representative
5. one representative of the Commissioner of Education
6. two residents at large from the city of Lewiston appointed by the mayor
7. two residents at large from the city of Auburn appointed by the mayor

The voices of those represented by the Council were heard both through meetings and individual interviews.

**FIGURE 1**  
**COMPREHENSIVE COMMUNITY COLLEGE CURRICULUM/  
 FACILITIES PLANNING MODEL**

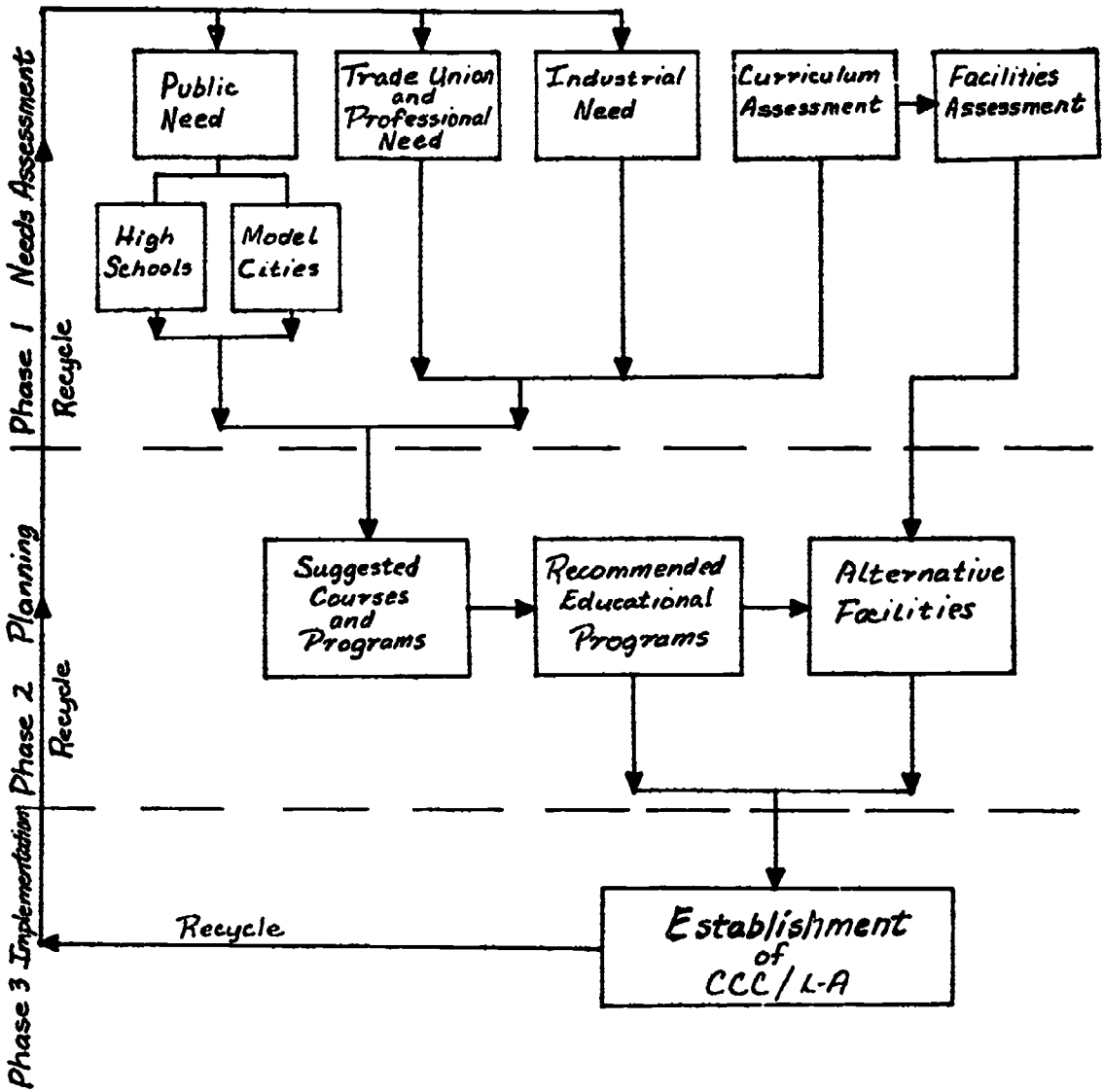

### **C. Review of Literature**

The two-year college is relatively new on the American scene. It was, in fact, born in this century. The two-year colleges, sometimes referred to as junior colleges but more recently as community colleges, have spread across the country. Two states, California and Florida, are recognized as leaders in the field. The idea is not new in the State of Maine. There are several institutions in Maine which offer community college type programs as listed in the Freeman report:

Central Maine Vocational-Technical Institute, Auburn  
Eastern Maine Vocational-Technical Institute, Bangor  
Washington County Vocational-Technical Institute, Calais  
Northern Maine Vocational-Technical Institute, Presque Isle  
Southern Maine Vocational-Technical Institute, South Portland  
Kennebec Valley Vocational-Technical Institute, Waterville  
Maine School of Practical Nursing, Portland and Waterville  
University of Maine at Orono, Orono  
University of Maine at Bangor, Bangor  
University of Maine at Portland-Gorham, Portland  
University of Maine at Augusta, Augusta  
Husson College, Bangor  
Thomas College, Waterville  
Bliss College, Lewiston  
Nasson College, Springvale  
Unity College, Unity  
Westbrook College, Portland  
Beal College, Bangor

As previously mentioned the community college is not new in Maine, and evidence indicates a continually growing interest in this type institution. It would seem that many educational leaders and lay citizens are viewing the community college as an important and distinct entity in future efforts to upgrade cultural, economic, and educational levels of the residents of Maine. Because of this growing interest, a two-fold review of literature was deemed as essential:

First, the review focused upon the wealth of available materials which discuss the community college in America - past, present and future. The importance of an understanding of the community college concept at this time in Maine cannot be overemphasized.

Second, the review included scrutinizing the higher education reports produced in Maine during recent years. It is to the credit of the educational leaders in the state that the concept of the comprehensive community college emerged in the state higher education planning reports.



## **D. Assessment**

Assessment is a basic planning tool which was considered vital to this study. Assessment was approached with the following questions in mind:

1. What are the post-secondary educational opportunities currently available in the Lewiston-Auburn area?
2. Who is taking advantages of these opportunities?
3. What kinds of educational program needs exist in the Lewiston-Auburn area?
4. What type of facilities are needed?

The assessment was made through utilization of surveys, personal interviews, and appropriate reports.

## **E. Analysis**

After all the data were collected, they were analyzed and synthesized for the written report.

### III. BACKGROUND

The study giving rise to this report was not an isolated project. It was, rather, a study which will hopefully take its place with a long line of significant studies concerned with higher education planning in Maine. It is within the context of these past studies that this report gains its significance.

#### A. State Reports Leading to Lewiston-Auburn Planning Project

It was in September of 1966 that higher education master planning in Maine began to take form with the Academy for Educational Development's Report (First Business of Our Times) to the Advisory Commission for the Maine Higher Education Study. In regard to master planning for the state of Maine, the report stated: "It is our belief that Maine has much to gain from a more planned and coordinated approach to higher education in the future, and much to lose without such an approach."

One of the more significant findings of the Academy's report was that the **greatest** higher education need in Maine at that particular time was for "... a much greater diversity of quality terminal and transfer post-secondary opportunities provided in modern facilities, with adequate libraries and laboratories, with instruction provided by trained faculty, and with a high status accorded such programs by education and laymen alike."

Moving on into the sections that deal more specifically with less-than-baccalaureate levels of education and training the Academy recommended the following:

The various campuses and branches under the proposed statewide University of Maine should be assigned program and service responsibilities as recommended in this report, including identification of certain campuses as University Community Centers. These centers should be established in Portland, **Auburn**, Augusta, Bangor, (Dow Campus), Fort Kent, and Machias, and they should provide a variety of terminal and transfer opportunities, offering certificates and associated degrees in vocational, technical, and general education for commuting students.

In response to the Academy's report, the Advisory Commission for the Higher Education Study recommended verbatim to the Governor and the Legislators of the State of Maine, January 14, 1967, the above cited recommendation of the Academy.

Thus, it was apparent in the beginning of master planning for higher education in Maine that community college centers need to be established and that the region in and surrounding Auburn was considered a key area for a community education center.

Over two years later in November, 1969, the Higher Education Planning Commission submitted a report to Chancellor Donald R. McNeil in which the need for one- and two-year programs was stressed and the following recommendations made:

1. The University should plan for immediate expansion of one-year and two-year program offerings at several locations.
2. Leadership, coordination, and budget control for two-year campuses should be provided at the Chancellor's Office.
3. A commitment should be made now to combine the vocational-technical institutes with the University of Maine at the end of the 1969-71 biennium.
4. A study should be commenced now to determine the conditions and procedures for that merger which will guarantee the integrity of vocational-technical education.
5. SMVTI should broaden its function to become a community college for Southern Maine.

The Board of Trustees, one month later on December 19, 1969, made the following statement regarding one- and two-year programs in the development of a higher education master plan:

We resolve that community colleges be added to the system to serve heavy population concentrations where there are no public higher education opportunities in the vicinity.

When financial resources are available and the priorities for expanded services are clearly established, consideration will be given to the needs of the Lewiston-Auburn area, the York County area, and the mid-coast area.

Again, emphasis is made on the need for community colleges with specific regard to the Lewiston-Auburn area and the beginnings of such community college centers at vocational-technical institutes.

During 1970, the publication, **Maine's Public Investment Needs of Highest Priority**, reported the following after examining previous suggested needs and organization for one- and two-year programs by other reports:

The need for less-than-baccalaureate and vocational-technical education is current and keen. There seems to be fairly general acceptance of the idea. The best and most economic organization for supplying the need is not clear. Further study is needed. . . . Meanwhile, all concerned with planning public investment should expect to make less-than-baccalaureate education whether of a general or technical nature a consideration of highest priority in the years ahead.

Another report was produced in 1970 by the Chancellor's Task Force on Less-Than-Baccalaureate Degree Programs which presented a majority report in favor of the establishment of community colleges which helped

to keep the issue alive. However, the report lacked considerable agreement on how it should be accomplished.

The Institute for Educational Development produced a document for the Higher Education Facilities Commission, in 1970, titled **Higher Education in Maine: Its Facilities and Utilization**. This publication revealed that construction of community college campuses in strategic locations would not be duplicating facilities unnecessarily, if the projected enrollment figures in Table 1 were reasonably accurate. Anticipated increase in enrollment in public institutions of higher education would require additional construction to accommodate future students. The following enrollment figures indicate the high rate of increase. In fact, the projected enrollment over an eleven-year period shows enrollment doubling on the University of Maine campuses and the Vocational-Technical Institutes.

**PUBLIC POST-SECONDARY EDUCATION INSTITUTIONS IN MAINE:  
ACTUAL (1968) AND PROJECTED (1977) ENROLLMENTS**

TABLE 1	Actual Enrollment 1968	Actual Enrollment 1971	Projected Enrollment 1977
University of Maine Campuses	12,680	15,975	20,370
Maine Maritime Academy	545	486	600
Vocational-Technical Institutes	1,423	1,909	3,850
Totals	14,648	18,370	24,820

Source: A report to the State of Maine Higher Education Facilities Commission, **Higher Education in Maine: Its Facilities and Utilization**, Charles F. Bragg II, chairman (New York: Institute of Educational Development, 1970), p. 13.

**B. State Reports Completed During the Project**

In February, 1972, Dr. Stanley L. Freeman, Jr. submitted a Special Opportunity Facilities Planning Project Report to the State of Maine Higher Education Facilities Commission which included the following statement of recommendation:

A community college development together with vocational-technical institutes can offer many people in various areas of the State an opportunity to continue their education beyond the high school level. . . Based on population, new facilities should be considered for less-than-baccalaureate programs in the York County area and the Lewiston-Auburn area. Although both of these

areas are within a reasonable commuting distance of institutions offering less-than-baccalaureate programs, increased student enrollment at these institutions will place extreme pressure on existing facilities which may be relieved by facilities within these two areas.

In April, 1972, the First Operational Report from the Higher Education Planning Commission was completed. Considerable attention was given to the need for community college programs and their development. The recommendations section in Chapter VI specified the educational need in Lewiston-Auburn in the following manner:

**Provide community college programs in Androscoggin County.**

Lewiston-Auburn is the second largest urban center in Maine. It is served by an excellent vocational-technical institute and several private colleges. It is plagued with high unemployment and low family income. An enrichment of the educational opportunities in the area with new two-year programs could help many young people and adults improve their employability. Planning for this expansion should be carried out jointly with local interests and the educational institutions in the area to achieve maximum use of facilities and instructional personnel which already exist. UMA might offer some of its programs through Continuing Education to the Lewiston-Auburn area.

In Chapter XII, three pages were set aside to discuss the community college concept and budget considerations. The following statement reveals an overriding emphasis of the report:

In keeping with the academic program described in Chapters III through IX, it is proposed to establish three Community Colleges during the period covered by this report. In so doing, enrollments are projected as shown in (Table 2). These enrollments represent the expanded enrollments set forth in Table 12.2. (the First Operational Report from the Higher Education Planning Commission)

The cost of constructing three community college facilities at three locations was estimated in Chapter XIII indicating the hopes and inspiration for community colleges.

In summary, the aforementioned reports on higher education master planning all emphasize the great need for Maine to establish comprehensive community colleges with Lewiston-Auburn as a top priority area.

**TABLE 2****COMMUNITY COLLEGE ENROLLMENTS — FTE**

	College A	College B	College C	Total
1973	340			340
1974	552	320		872
1975	591	591	373	1,555
1976	743	743	743	2,229
1977	1,074	1,074	1,075	3,223
1978	969	970	970	2,909
1979	1,264	1,265	1,265	3,794
1980	1,369	1,369	1,369	4,107

Source: First Operational Report from the Higher Education Planning Commission

## IV. PHILOSOPHY AND FUNCTION OF THE COMMUNITY COLLEGE

The most striking recent structural development in higher education in the United States has been the phenomenal growth of community colleges. Community colleges have gradually broadened the concept of the traditional junior college role as lower division institutions, primarily concerned with preparation of students who are qualified to transfer to senior colleges and universities, to include meaningful options for students who have not yet made a firm career choice, to provide opportunities for cultural improvement, and to meet the need for programs of education for adults. The emergence of community colleges has been influenced by such factors as the rapid scientific and technological development, the trend toward an egalitarian society, and the increasing complexity of social and political issues at home and abroad. Such factors have led not only to the necessity for more education for more people, but also to a belief on the part of an increasing proportion of the people that various types of post high school education are a necessity for them and their children. This, in turn, has resulted in a demand for a broader base for higher education and for easier access to it.

The more complex society becomes, the more necessary the need to develop each individual to his full potential. High school graduation is no longer a satisfactory terminal point for the majority of students. On the other hand, not all students desire or need to attempt a traditional baccalaureate program. The learning process will continue to absorb time and effort of more Americans throughout their lifetime. Opportunities for higher education and the fulfillment it affords should be available to persons all through life and not just immediately after high school. The comparative newness of community colleges requires that any planning be preceded by a clear explanation of their function and philosophy.

### **Overview of Community Colleges**

Within its 335 years of development American higher education has had three significant periods. Primarily developed to educate the elite, higher education moved toward mass education and from there to the current trend of universal-access higher education.

In the decade of the 1960's the universal educational access principle, regarding post-secondary education, began to engage the serious consideration of educators and political leaders. In the preface to Sutton's report, Ocherman stated:

The decade of the 1960's witnessed the appearance of a Quiet Revolution in higher education, the rapid growth of two-year or

community colleges. While evolutionists and revolutionists attempt to continue their headline grabbing demands for education that is "relevant to our times," one of America's greatest transitions in higher education is quietly taking place in America's newest colleges. It can be contended with substantial validity that no other change has had such a profound effect upon the educational scene and yet received, comparatively speaking, so little attention and critical examination (20, p. 1).

The traditional four-year undergraduate program, usually equated with higher education in the minds of many Americans, does not provide an adequate system of higher education that is needed today, and should not be necessarily the standard educational experience for all Americans. Rather, in view of a rapidly changing society, a system must be created that offers a wide variety of options to the individual.

The community junior college movement in the United States is the most current dramatic development in higher education. It began with the establishment of a junior college in Joliet, Illinois, in 1901. During the 1960's an average of one post-secondary, two year institution was opened per week. The total number of these institutions is approaching 1,000. Of this number approximately 750 are public community colleges (7, p. 185).

Community junior colleges may be described as institutions supported by public tax funds and controlled and operated by a board which is either elected or appointed by a public official or agency. They offer programs, or courses, limited to the first two years of post-high school education. These include programs parallel to the freshman and sophomore years of a baccalaureate degree granting institution, occupational education especially at the technical and mid management levels, and continuing education opportunities for those who have either graduated from high school or have passed the age of the usual high school student (15, p. 2).

The role of higher education is largely affected and developed by trends in American society. With the present focus on two-year community colleges, educational planners must face the departure from traditional methods in light of the innovation and change necessary to the entire structure of higher education.

The trends in American life will affect educational planning far more than educational trends, according to Glenny and Weathersby, who stated: Education is not the dog that wags the tail of society. Educational programs, policies, and plans are only part of larger patterns. And to anticipate what American education beyond the high school will be a decade from now, one must first deduce what American Society will be (10, p.43).

The two-year colleges and specialized institutes are the most rapidly growing institutions in American higher education. In statistics quoted by



the Carnegie Commission Report of 1970, they accounted for 38 percent of all institutions and for 28 percent of the students (2, p. 2).

The dilemma of educational planners today is how to provide educational programs for everybody without the depersonalization usually accompanying mass education. Pfeiffer stated that the student must not become lost in a colossal system of fifty million others, or else a harvest of drop-outs and disenchanting will be reaped (16, p.7)

Certain considerations faced by educational planners include the following:

Young people should also be given more options: (a) in lieu of formal college, (b) to defer college attendance, (c) to stop out from college in order to get service or work experience, and (d) to change directions while in college (1, p. 1).

and, most significantly:

Opportunity for higher education and the degrees it affords should be available to persons throughout their lifetimes and not just immediately after high school (1, p. 1).

In such developments the Federal Government can play an important role of assistance by:

Assisting the spread of community colleges across the 50 states.

Giving support to student in all post-secondary education, as it did after World War II in the GI Bill of Rights, and not just to those in formal colleges (1, p. 25).

The importance of the scope of the community college and its rapid rate of growth is schematically presented in Figure 1.

In such a "learning society" the role of the community college plays an important part in providing the technical competence and instruction for a better life. This fact appears to be recognized by a large part of the student population. As Glenn and Weathersby state, "Here, where instruction and life-long education are stressed, enrollments are burgeoning" (10, p. 10).

Figure 2

CHANGES IN DISTRIBUTION OF TOTAL ENROLLMENT IN HIGHER EDUCATION, BY TYPE OF INSTITUTION, ACTUAL, 1963 AND 1970, AND PROJECTED, 1980 TO 2000

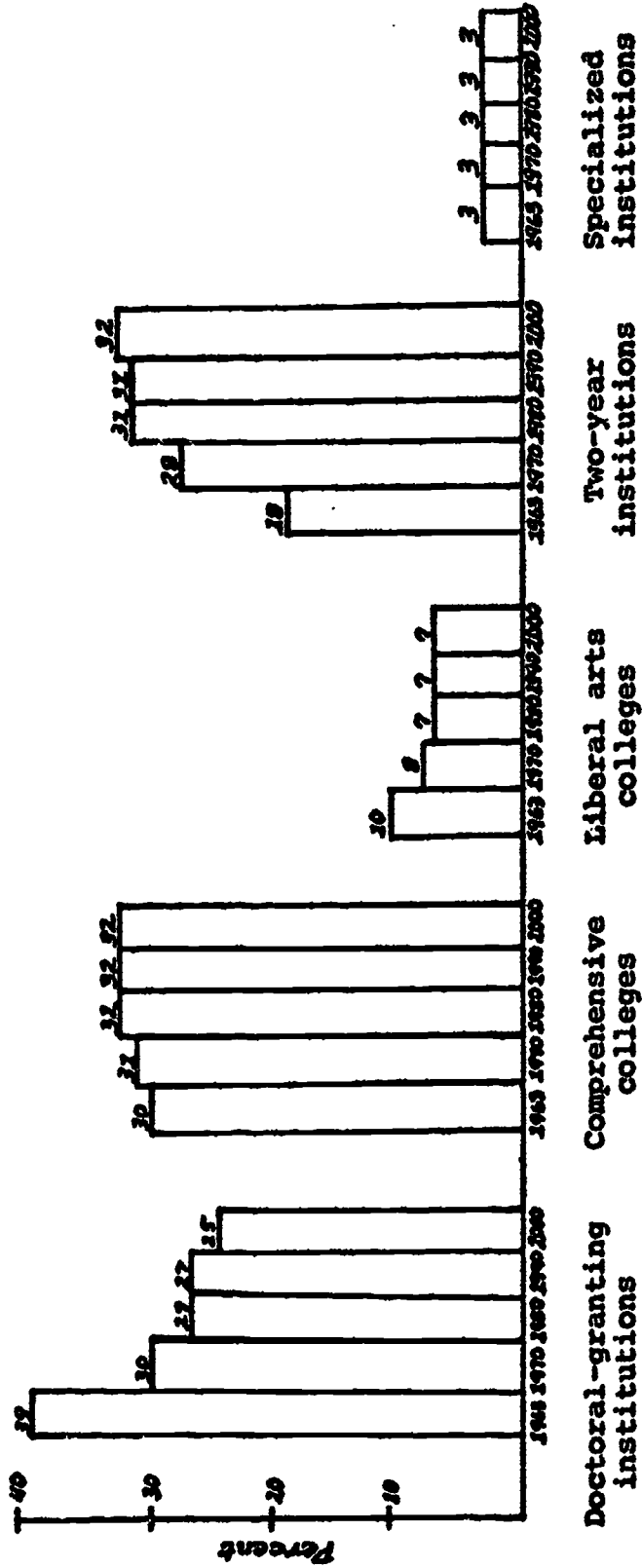

SOURCE: Carnegie Commission Report, New Students and New Places, p. 46.

## **Higher Education — For Whom?**

Higher education in America was primarily developed for the elite. The 1940's marked the movement toward mass education and, now, in the 70's it is moving toward universal access higher education.

More people will be educated to a greater degree in American society than never before in the history in any nation (2, p. 9). Such education carries a high degree of responsibility for the American citizen:

Contemporary American society, technocratic and complex, contains singular opportunities and problems. Its technocracy and affluence affords most of its citizens a style of life in terms of goods, services and leisure that is unprecedented. Yet, America's citizens must be unusually enlightened and competent in order to make appropriate uses of its opportunities and at the same time deal with its problems. It is quite possible that universal higher education has become a major means, if not a prerequisite, for such a citizenry. In this context, the national goal of providing higher education for all who can profit from it appears not just commendable, but essential (22, p. 1).

The Carnegie Commission on Higher Education stated their belief that:

... access to higher education should be expanded so that there will be an opportunity within the total system of higher education in each state for each high school graduate or otherwise qualified person. This does not mean that every young person should of necessity attend college — many will not want to attend, and there will be others who will not benefit sufficiently from attendance to justify their time and the expense involved. Thus, we favor universal access but not universal attendance in our colleges and universities. Within the system of higher education, the community colleges should follow an open-enrollment policy, whereas access to four-year institutions should generally be more selective (2, p. 103).

At present, American society still distributes opportunities for higher education with great disparity. According to the Carnegie Commission Report of 1971, **Less Time, More Options:**

Degrees are more available to the young than to the middle-aged and the old; to men — at a time they can readily be used — than to women; and to members of the higher than to the lower income groups. The American dream promises greater equality than this, and American reality demands that age be served as well as youth, that women be served equally with men, and that the poor be served as well as the rich (1, p. 10).

The community college represents a conscious effort to provide universal opportunity for higher education. According to Wattenbarger, Cage and Arney, planning has been carried out in several states to make this goal of elementary and secondary education a goal of higher education also (15, p. 31).

It is very apparent to educational planners that the increasing complexities of American society necessitate the development of each individual to his full potential. Chairman of the Chancellor's Task Force, Edward Blewett, stated:

High school graduation was once a satisfactory terminal point for a majority of students, but this is no longer so. New social problems at home and abroad have brought about the need for deeper insights. A new world of science has created a vacuum for those with no scientific knowledge. Development in technology and automation have reduced the number and importance of many occupations and have given rise to new ones which depend more upon understanding than upon manipulative skill. The need to provide sufficient educational opportunities beyond high school for those who can profit from such opportunities, and to encourage people to take advantage of them, is clear (18, p. 1).

### **Term "Comprehensive" is Added**

The public two-year college is committed to provide a variety of educational programs in order to fulfill the needs of everyone. Because of the diversity of their program, the name has gradually changed from "junior college" to "comprehensive community college" (7, p. 88). By virtue of their geographic base, they become community institutions as well. This fact implies, according to Newman, a "mission of community orientation distinct from most other institutions of higher education" (19, p. 58).

In describing the development of an institution designed to meet such divergent needs, the Report of the Center for Research and Development in Higher Education stated:

To develop a college for the diversified student body that presents itself at the open door of the community college is a formidable task. The array of talents and goals is great. There is the average student who is not quite sure he can make it at the university; there is the bright one who can't afford to leave home and a job to go away to college; there is the poor student who lacks even the basic learning skills but who recognizes the importance of preparing for a career; and there is the student from a minority group who sees the community college as a bridge to equal opportunities. There is the housewife who seeks cultural enrichment and the technologically obsolete family man who wants job

retraining. It is no wonder that community colleges have added the word "comprehensive" to their titles (5, p. 4).

The educational services of the comprehensive community college are spelled out by the Chancellor's Task Force within a program of accessibility and minimal cost. The programs offered are:

- a. educational and occupational guidance and counseling
- b. courses for personal satisfaction
- c. courses for remedial purposes
- d. make-up courses for deficiencies
- e. general education, regardless of occupational objectives
- f. the first two years of a four-year baccalaureate degree program
- g. social and cultural attitudes and appreciations for individual and community needs
- h. occupational education on a continuing basis for both pre-employment and upgrading purposes (18, p. 4).

The programs appear to be divided into the broad categories of general studies, career opportunities, and remedial programs (18, p. 4). The importance of remedial programs is underscored by Cosand's findings:

In four-year colleges . . . the trend is to cut back on remedial work. The ill-prepared or unmotivated student will usually fail or drop out. Not all junior colleges, to be sure, have a remedial program (some have highly selective admission policies), but the truly comprehensive community college usually shows a real concern for helping the student to succeed by showing him how to try. While students are not coddled, they do receive help in remedying their deficiencies and developing their innate talents (6, p. 134).

In addition to Cosand's findings, the Carnegie Commission on Higher Education reports the drop-out rate from higher education to about 60 percent (1, p. 9). Without receiving much recognition for their efforts, the dropouts leave with a sense of disappointment and even resentment (1, p. 9).

According to Cross, national agreement is developing on the difficulty of classification by curriculums. Educators have roughed out a three-way classification scheme consisting of:

- (1) college parallel; (2) 2-year technical programs, including science-related programs such as engineering and industrial technologies, health technologies, and nonscience curriculums at the technical level such as business and commercial arts; and (3) vocational programs of less than 2 years duration such as practical nursing, auto mechanics, secretarial training, etc. (7, p. 190).

In attempting to meet the needs of all in the community, continuing education for adults is an important educational service of the community college. In a recent report Cross estimated:

. . . there are about 17 million adults enrolled in courses, and many of these are attending community colleges. While most adults are part-time students, full-time students over 21 make up 7 percent of the junior college population but less than 2 percent of the enrollment of 4-year institutions. Another way of stating the importance of adult education in the community colleges is to observe that part-time students constitute 46 percent of the total student enrollment in community colleges and 35 percent of the total 4-year college enrollment (7, p. 192).

These figures represent a third to nearly half of a community college enrollment being represented by adults (15, p. 32). With the expected population increase of 46 percent in the 25 to 34 age group by 1980 — three times the increase in the age group of 15 to 24 — the need for continuing adult education is paramount in higher education today (15, p. 122). Tables 3 and 4 show the community college projections for 1970 and 1980 as based on the projected population of the United States.

TABLE 3

**UNITED STATE PROJECTED POPULATION  
BY AGE GROUPS FOR  
1970 and 1980**

Age Group	1970	1980	Increase	Percent Increase
15-24	36,361,000	41,876,000	5,515,000	15
25-34	25,315,000	36,997,000	11,682,000	46
Over 34	84,363,000	91,618,000	7,255,000	9
15 and over	146,039,000	170,491,000	24,452,000	18

Sources: James L. Wattenbarger, Bob N. Cage, L. H. Arney, National Education Finance Project, Special Study No. 6, **The Community Junior College Target Population, Program Costs and Cost Differentials** (Gainesville, Florida: Institute of Higher Education, University of Florida, 1970), p. 33.

U. S. Bureau of the Census. **Current Population Reports, Series P-25, No. 381.**

**TABLE 4**

**COMMUNITY COLLEGE PROJECTIONS FOR  
1970 and 1980 BASED UPON  
VARIOUS NUMBERS PER 1000  
TOTAL POPULATION**

	1970	1980
U. S. Population Projections	206,342,000 <sup>a</sup>	242,307,000
	203,940,000 <sup>b</sup>	226,681,000
<b>Number Junior College Students</b>		
①		
20 per 1,000	4,126,840 <sup>a</sup>	4,836,000
	4,078,000 <sup>b</sup>	4,533,620
30 per 1,000	6,190,260 <sup>a</sup>	7,269,210
	6,118,200 <sup>b</sup>	6,800,430
40 per 1,000	8,253,680 <sup>a</sup>	9,692,280
	8,157,600 <sup>b</sup>	9,067,240
50 per 1,000	10,317,100 <sup>a</sup>	12,115,350
	10,197,000 <sup>b</sup>	11,334,050

Sources: Wattenbarger, Cage and Arney, *The Community Junior College Target Population, Program Costs and Cost Differentials* p. 33.

<sup>a</sup>U. S. Bureau of the Census, Current Population Reports, Series P-25, #375, "Revised Projection of the Populations of States: 1970 to 1985," Series I, pp. 42-49.

<sup>b</sup>U. S. Bureau of the Census, Current Population Reports, Series P-25, #375, "Revised Projections of the Population of States: 1970 to 1985," Series II, pp. 42-49.

**Growth of the Community College**

At the beginning of the present century, there were only a few two-year college students. By 1960, more than 600,000 students were enrolled in two-year institutions of higher education and, by 1969, their numbers had grown to almost 2 million, including both full-time and part-time students as shown on Figure 5. These students accounted for nearly 30 percent of all undergraduates and 25 percent of all students in higher education in the nation (3, p. 3). The percent of undergraduates enrolled in two-year institutions of higher education, by state, in 1968, is depicted on the map.

## **Community College Needs in the State of Maine**

The State of Maine has experienced a growing concern regarding educational opportunities for its citizens. Former Governor Reed expressed the changing attitudes toward education in the State:

There can be no understatement of the importance of the role that education and an educated citizenry must play in Maine's economic future. Without an efficient educational system of elementary and secondary education and an adequate opportunity for higher education this state cannot expect to progress and improve its status, culturally, economically, or in any other way . . . . In fact, education actually is the first business of our times (8).



**Figure 3 Enrollment in two-year colleges, United States, 1930-1970**

Number in thousands

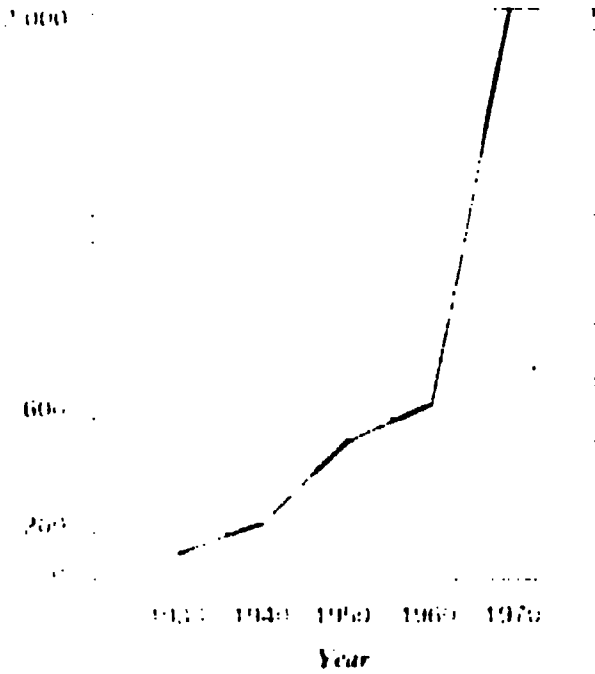

Source: Adapted from American Council on Education data, with estimated 1930 enrollment.

**Figure 4 Characteristics of students in two-year colleges**

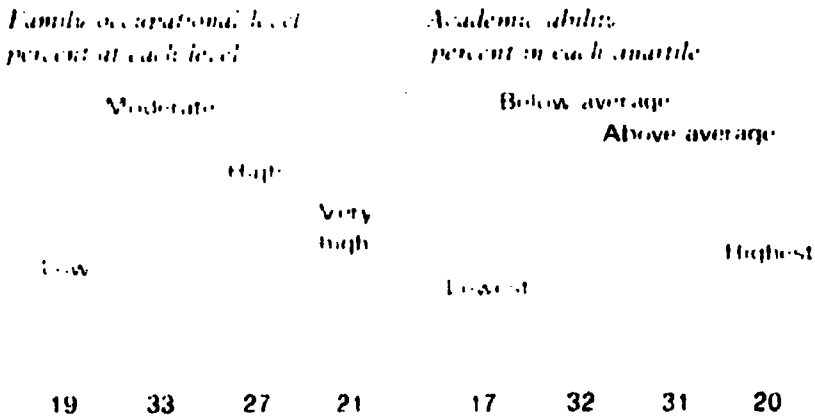

Source: Survey conducted by the Center for the Study of Alternative Illinois, Massachusetts, and North Carolina by SOCIETY FOR RESEARCH AND DEVELOPMENT IN HIGHER EDUCATION, University of California, Berkeley.

**BEST COPY AVAILABLE**

**Figure 5 Percent of undergraduates enrolled in two-year institutions of higher education, by state, 1968**

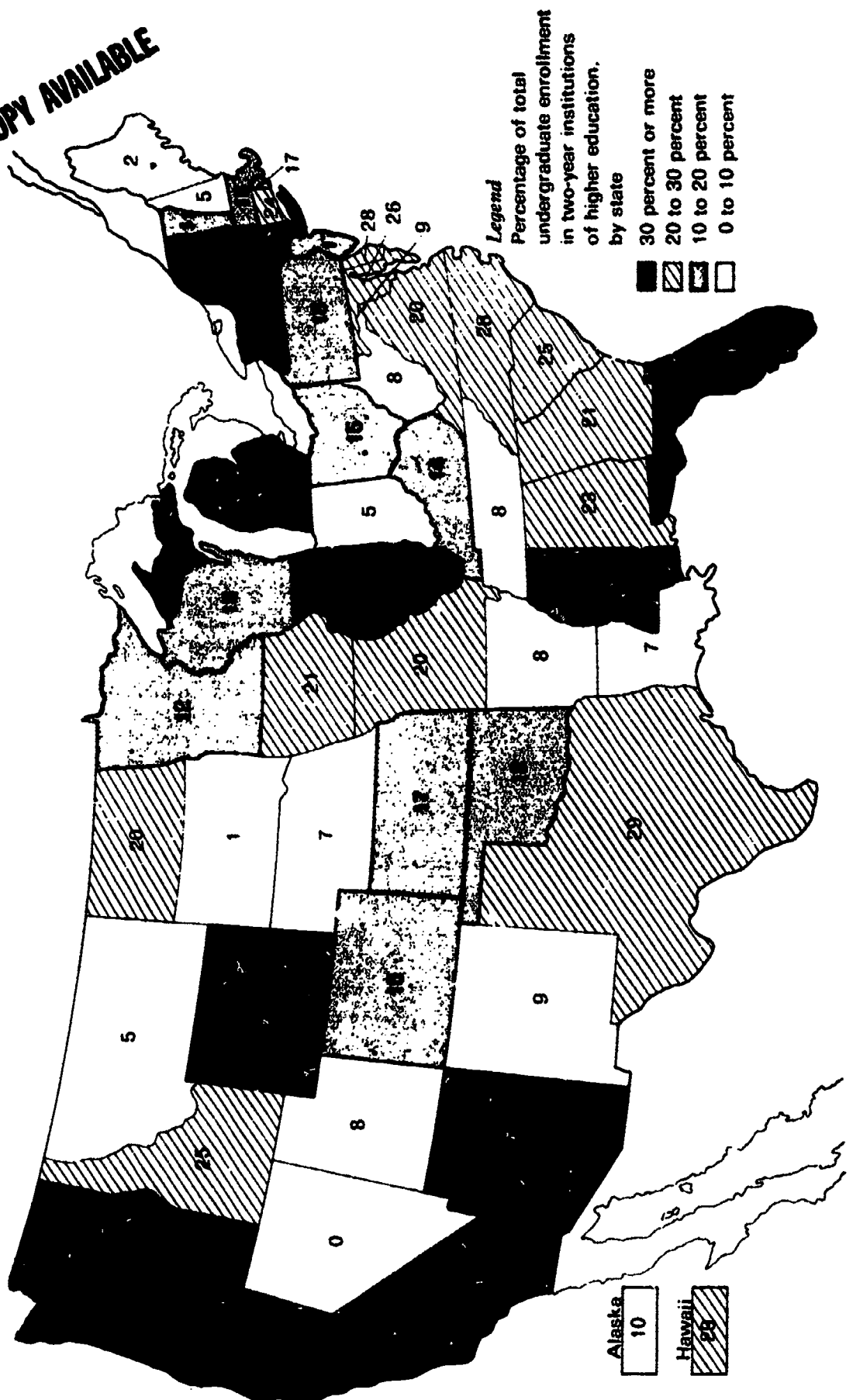

The concern of the Governor was quickly appropriated by the State Legislature. The preamble of Chapter 400 of the Public Laws of the State of Maine enacted by the 103rd Legislature in 1967 stated:

The people of Maine are desirous of, and entitled to, equal opportunity for a quality post high school education.

We declare that we can no longer afford to waste any of our human resources, that higher education must be made available to our youth irrespective of economic status or geographic location.

We declare our responsibility to recognize education as a continuing need of our people and to afford widespread opportunities in adult education (17).

The recent dedication to public education must be considered in context of the history of Maine. For several generations Maine's level of support of public education has been low on a per capita, and on a personal income basis, when compared to other states (12, p. 23). The Coles Report revealed Maine's low degree of support for higher education:

In 1965, only nine states spent less per capita for post-secondary education than Maine, while twenty-one states spent more than twice the \$20 per capita spent by the State of Maine. In 1965, thirty-seven states, including New Hampshire and Vermont, spent more per \$1,000 of income than did the State of Maine; of the 15 states having lower per capita personal incomes than Maine, all spent a higher per cent of personal income for public higher education than did Maine (12, p. 23).

Obviously, the state has failed to support public higher education adequately.

The people of Maine want, and have a right to expect, a system of education which is responsive to social change, and at the same time responsible for it (8, p. 10). The people want and expect:

. . . a system which meets needs and creates new ones; a system which both follows and leads; a system in which "access" will vary from restrictive to permissive; a system in which "substance" will range from the avocational to the professional and in which "kind" will range from the casual to the highly organized. This is a large order for higher education in the state of Maine, portending for the future many uncommon challenges which must be met rapidly and forcibly by uncommon solutions (8, p. 10).

The focus of these expectations is people. Educational programs at all levels are means, not ends. Their purpose is to confer benefits and their nature is thus the concern principally of the beneficiaries. For example, two kinds of benefits a student may result from higher education programs:

(1) improvement of occupational and intellectual life, and (2) benefits which derive from the educational environment itself (9, p. 5).

Several states have developed an extensive community college system. In 1960, California adopted a master plan for higher education which became a landmark in the evolution of community colleges into fuller status within higher education. The California story may serve to illustrate the potential impact and outreach of a statewide community college system, as their Master Plan provides opportunity for higher education to nearly everybody:

The plan provides that the university was to maintain high admission standards, selecting first-time freshmen from the top one-eighth of all graduates of California public high schools and from graduates with equivalent records at private and out-of-state secondary schools. The university was also to give relatively greater emphasis to upper-division and graduate work than to lower division instruction. The state colleges were to select their first-time freshmen from the top one-third of all graduates of California public high schools and from graduates of private and out of state secondary schools at equivalent levels. Although there was no specific recommendation in the master plan with respect to the admission policies of community colleges, the California code requires community colleges, assuming requirements are met, to accept "any high school graduate and any other person over eighteen years of age . . . capable of profiting from the instruction offered" (3, pp. 10, 11).

### **Education Priorities in Maine**

The State Planning Office published **Maine's Public Investment Needs of Highest Priority** in October, 1970. The document recommends that the state adopt as a policy, and provide appropriate funding for, a state-wide system of comprehensive community colleges. Indeed, they report that highest priority should be given to the need to develop a state-wide system of community colleges (13, p. 128). The Academy for Educational Development report to the Advisory Commission for the Higher Education Study, State of Maine, September, 1966, was an early report which singled out the community college needs. The report stated:

. . . the greatest higher-education need in Maine at this time . . . a need that will have to be met for many years to come . . . in for a much greater diversity of quality terminal and transfer post-secondary opportunities provided in modern facilities, with adequate libraries and laboratories, with instructions provided by trained faculty, and with a high status accorded such programs by educators and laymen alike (8, p. 54).

The Advisory Commission for the Higher Education Study indicated that the comprehensive community college is the best vehicle for providing certain "basics" in higher education to which all citizens in Maine should expect ease of access regardless of their geographical location or their financial resources. The basics are:

1. General academic programs which enable students to complete the first two years of college with associate degrees and transfer, if they desire, to a four-year program as a junior.
2. Two-year technical programs offering associate degrees and one- and two-year vocational programs designed for employment in a great variety of areas. These should be quality programs which may lead to immediate employment or possibly carry some transfer credit to four-year programs.
3. Remedial programs planned for "late bloomers," for under-achievers, and for those who are ill prepared (because of cultural, financial, or psychological reasons) which permit such students another opportunity to make up deficiencies and thus to qualify for admission to a transfer, technical, or vocational curriculum.
4. Continuing or adult education programs which will enable adults to upgrade themselves culturally as well as occupationally.
5. Closely articulated counseling programs in the schools and colleges aimed at assisting students to match their study and occupational interests with their abilities and to pursue education to the limits which they may set (8, p. 53).

## **Community Colleges and the Economy**

The relationship of a quality statewide system of comprehensive community colleges has been underscored in the state reports. The Report of the Chancellor's Task Force on Less-Than-Baccalaureate Degree Programs, May, 1970, stated that the vocational-technical institutes and the two-year associate degree business programs are not producing enough trained workers for the available jobs in Maine (18, p. 3). In fact, to fill current needs in Maine employment, approximately eight times as many persons should receive one- or two-year training in post-secondary education as the number who attend four-year colleges (19, p. 3). Presently, more students in Maine are enrolled in public four-year institutions than in less-than-baccalaureate degree programs.

The Advisory Commission for the Higher Education Study was aware of the economic implications of a statewide system of community colleges. The Commission recognized that programs in these institutions could lead

to immediate employment or to transfer to the four-year college; however, the emphasis of the Commission was upon immediate employment.

## **Planning Considerations**

Developing a statewide system of comprehensive community colleges requires a state-level planning component. Those responsible for development of new institutions require assistance and information regarding needed educational programs, buildings to house the programs, and long-range planning to guide future growth (11, p. i). An early question in the planning phase is: Is it feasible to establish a Community College? The study to provide essential information should focus upon such matters as characteristics of the population, assessed valuation of property, together with local business and industrial needs. In **A Guide for Planning Community Junior College Facilities**, suggestions are listed for the local committee which should be involved in the planning process:

As its first priority, therefore, the local committee should determine the statutory provisions for the establishment of a community college and find answers to such questions as:

1. What are the State requirements for establishing a community college? What are the characteristics of the local population, and the extent of unmet labor needs?
2. Has a guide been developed by the State showing a step-by-step approach to obtaining approval of a community college?
3. Has the State completed a long-range plan for higher education or for community colleges? If so, does the plan give a priority for the establishment of a college in the community?
4. Is State money available for a feasibility study? How can such assistance be obtained?
5. Will the State approval agency provide leadership to the local committee for conducting the feasibility study? (11, p. 4).

States which have implemented a state-wide community college system recommend provision for adequate planning time. Legislators in selected states reported:

. . . the junior colleges had been developed in such haste and for such a variety of purposes that it was necessary to define more carefully their role in the state's educational plans and to coordinate their activities and growth with those of the four-year institutions. Such criticisms were made, however, not in the desire to curtail junior colleges but to make them more effective (4, p. 113).

Without state-level planning and control, a state may end up with more community colleges than it needed or could afford and their geographical

distribution may be determined more by political than by educational factors (4, p. 113).

## **Change and Planning**

Rapid change has become a part of the American way of life. Certainly, all change is not the result of planning. Indeed, most change occurs due to a lack of planning or in spite of planning. Planning may have as one of its objectives designing appropriate responses to change. The Coles Report, *Higher Education in the State of Maine*, was aware of the interaction of planning and change:

Change for its own sake is not necessarily beneficial. Change well justified, and carried out according to a carefully conceived plan, flexible enough to respond to changing conditions and needs, can result in better, fuller and wider ranging higher educational programs and more education for each tax dollar spent, than will uncoordinated, uncontrolled, unintegrated growth (12, p. 6).

Statewide planning must not only understand the present structure of post-secondary education within the state but also the trends in education. However, the changing needs of the society at large are far more important to consider than the trends within education (10, p. 62). This seems to be the point made in the Coles Report.

## **Statewide Planning in Maine**

The numerous reports on higher education which have been produced in the past eight years indicate Maine's commitment to statewide planning. In *Report of the Chancellor's Task Force on Less-Than-Baccalaureate Degree Programs*, Blewett stated: "We have led Maine people to believe that in order to succeed they must get more education. We are seriously in error when we do not provide for that education (18, p. 2)." The Coles Report addressed the fact that too few of Maine's citizens receive post-secondary training or education:

Basically, Maine is faced with the situation in which too many of its men and women of college age do not continue their education beyond the high school, either through lack of knowledge of opportunities which do exist, lack of funds, or lack of motivation. Any one of these reasons is equally costly to the deprived individual, and to the people of Maine as well (12).

The reports produced for the state seem to agree that statewide planning which aims at developing a master plan for higher education in Maine is essential. The Consultant Panel which wrote *The First Business of Our Times* identified certain characteristics which the master plan should have.

One important component in community college planning concerns the involvement of citizens from the community. This is a necessity if the institution is to meet the economic needs of the people, the community and the state. In this context the Coles Report recommended that efforts should be exerted to make greater use of local business, labor, and industrial leaders in the development of needed new programs in vocational and technical education: (12, p. 22).

### **Planning — Jobs — Programs**

Planning for comprehensive community colleges in the state, much more than for conventional four-year institutions, must focus upon available work opportunities in the area **and relating programs to them**. This is, in fact, one of the primary justifications for developing a statewide system of strategically locating community colleges in Maine. The McCain Report referred to the loss in human and economic resources which resulted from failure to develop an effective post-secondary system of education which is accessible to all citizens:

If young people in a particular state are isolated too long from the enlarged educational opportunities they need, they will either leave their state to fill their needs (and probably never return) or accept gracefully their obsolescence, passing it on from generation to generation with obvious consequences for themselves, the local and state school system, and the economy, too (8, p. 52).

In the final report **Higher Education Planning for Maine**, statistics are given which show that although Maine leads the nation in the proportion of the population which has completed high school, it was still **lowest among all fifty states** in 1968 in the rate of high school graduates attending college. This discrepancy suggests that the immediate target for higher education must include the adult as well as the youth of Maine, for many children lack the encouragement to give college serious consideration when their parents have had no experience with higher education.

Planning programs to match community needs is an ongoing process. Educational requirements change, which necessitates keeping opportunities for education accessible throughout life (18, p. 4). In reference to the fact that jobs have changed, and are changing, the Carnegie Commission stated: "Rather than long-extended formal education in advance, more jobs require some basic skills and knowledge in advance and then a willingness to keep on learning and opportunities to learn" (1, p. 8).

### **The Community College in the Proposed State Structure**

The Academy for Education Development (AED) report, **The First Business of Our Times**, September, 1966, outlined a new structure which in-



cluded all post secondary institutions in the state. The new structure, if implemented, will have a far-reaching effect upon the comprehensive community college development in Maine. The Report recommended that:

The Board of Trustees of the University of Maine (enlarged to 15 members) should constitute the public body responsible for the development of policy with respect to the planning, coordination, and conduct of all public higher education in the state of Maine. The primary responsibilities of the trustees should be:

1. The appointment of a president who should be the chief administrative officer for all public higher education;
2. the development and presentation of the operating and capital budget requests to the Governor and State Legislature;
3. the overseeing of all construction for public higher education; and
4. the development and publication of a master plan for all aspects of public higher education in the state of Maine.

The programs and facilities of the five state colleges, the four vocational-technical institutes, the Maine Maritime Academy, and all present and future branches and campuses of the University of Maine should constitute the public state-wide system of higher education and be appropriately identified and administered as an integral part of the University of Maine.

The various campuses and branches under the proposed state-wide University of Maine should be assigned program and service responsibilities as recommended in this report, including the identification of certain campuses as University Community Centers. These centers should be established in Portland, **Auburn**, Augusta, Bangor, (Dow Campus), Fort Kent, and Machias, and they should provide a variety of terminal and transfer opportunities, offering certificates and associate degrees in vocational, technical, and general education for commuting students (8, pp. 1, 2).

The significant statements in the recommendation are those which collect all higher education institutions into one unit and place one administrator over the entire level. The administrator is responsible to the President or Chancellor of the University of Maine. All programs and facilities in the statewide system present and future, are to be under his management.

To further clarify its position the consultant panel which generated the report stated that:

The public one- and two-year terminal and transfer programs in vocational, technical and general education should be an integral

part of the state's system of public higher education and offered on the branches, campuses, and centers of the University of Maine. To this end, the university should create a division responsible for the development and administration of one- and two-year programs to carry on the necessary planning, the training of teachers for these programs, the essential research and development, and program-development liaison with secondary schools. Policy-making for such programs should be the responsibility of the university's Board of Trustees or of a separate body reporting to the trustees. Programs of technical and vocational education should have a distinct budget within the university's total budget (8, p. 62).

The Higher Education in the State of Maine Report, 1967, accepted the AED recommendation regarding a unified system of higher education: The Commission believes that the higher education needs of the State of Maine can be met most effectively and rapidly and at the most reasonable cost to the taxpayers of the State of Maine and to the maximum benefit of the State's educationally deprived if a single unified university system of public higher education is established (12, p. 10).

To clarify its position the Commission recommended:

That the Legislature should take such steps and actions as are necessary to incorporate all existing public higher education institutions in the State of Maine including the University, the five State Colleges, the four Vocational-Technical Institutes, the Maritime Academy, and any branches, campuses, or schools maintained by these institutions which might be established, into a statewide university system under the name and authority of the University of the State of Maine. Legal and full control of the aforementioned institutions shall be transferred to the Trustees of the University of Maine on July 1, 1968.

In 1969, the Higher Education Planning Commission issued a "Progress Report" to the Chancellor, University of Maine, recommending that all post-secondary institutions be combined under the Chancellor, but added that a separate division of less-than-baccalaureate degree programs be established within the Chancellor's office (17, p. 9).

The University Chancellor announced in May, 1970, that the number one priority for the next biennium is going to be the development of one- and two-year programs on all campuses of the University (13, p. 140). It would seem that the AED recommendation with regards to one- and two-year programs, 1966, has been generally accepted in the state, and it is being implemented on a gradual basis.

The Commissions recommend the unified or statewide university structure have done so after consideration of Maine's particular situation and needs, and in terms of the youth, population, existing institutions, geography, and resources in the state (12, p. 7). However, reorganization of the higher education system has not been completed. The Vocational-Technical Institutes have not been transferred to the University of Maine. Figure 6 illustrated the current structure of public post-secondary institutions.

## **Proposed Structure Options**

Opposition has begun to surface regarding the inclusion of community colleges and vocational-technical institutes in a unified system and as a part of the University of Maine system. The **Report of the Chancellor's Task Force**, May, 1970, contained a section entitled "Statements of Expositions." Blewett and Frey reported:

It would appear, however, that if Maine is to have and enjoy a successful development of less-than-baccalaureate degree programs in comprehensive community colleges, it had best establish these as separate institutions not affiliated with the University or the State Board of Education.

The evidence is clear in state after state across the nation. The comprehensive community college flourished best when it is a separate institution; where administration, faculty, and students share a single purpose; namely, the successful education of the two-year (or one-year) student. There is no need to share teaching between two-year and four-year or graduate students. There is no denigration (disintegration) of the two-year student as frequently happens in the four-year college. There is a great sense of community and it is possible to make a united effort in behalf of institutional development (18, p. 18).

The State Planning Office publication, **Maine's Public Investment Needs of Highest Priority**, October, 1970, also contained a word of caution. Having expressed thoughts similar to Blewett and Frey, the report stated: "National experience shows clearly that separate two-year colleges justify their creation without question when their purpose is clear to all concerned" (13, p. 140).

**BEST COPY AVAILABLE**

**Figure 6**

Organization of the State of Maine Higher Educational Institutions as of 1971

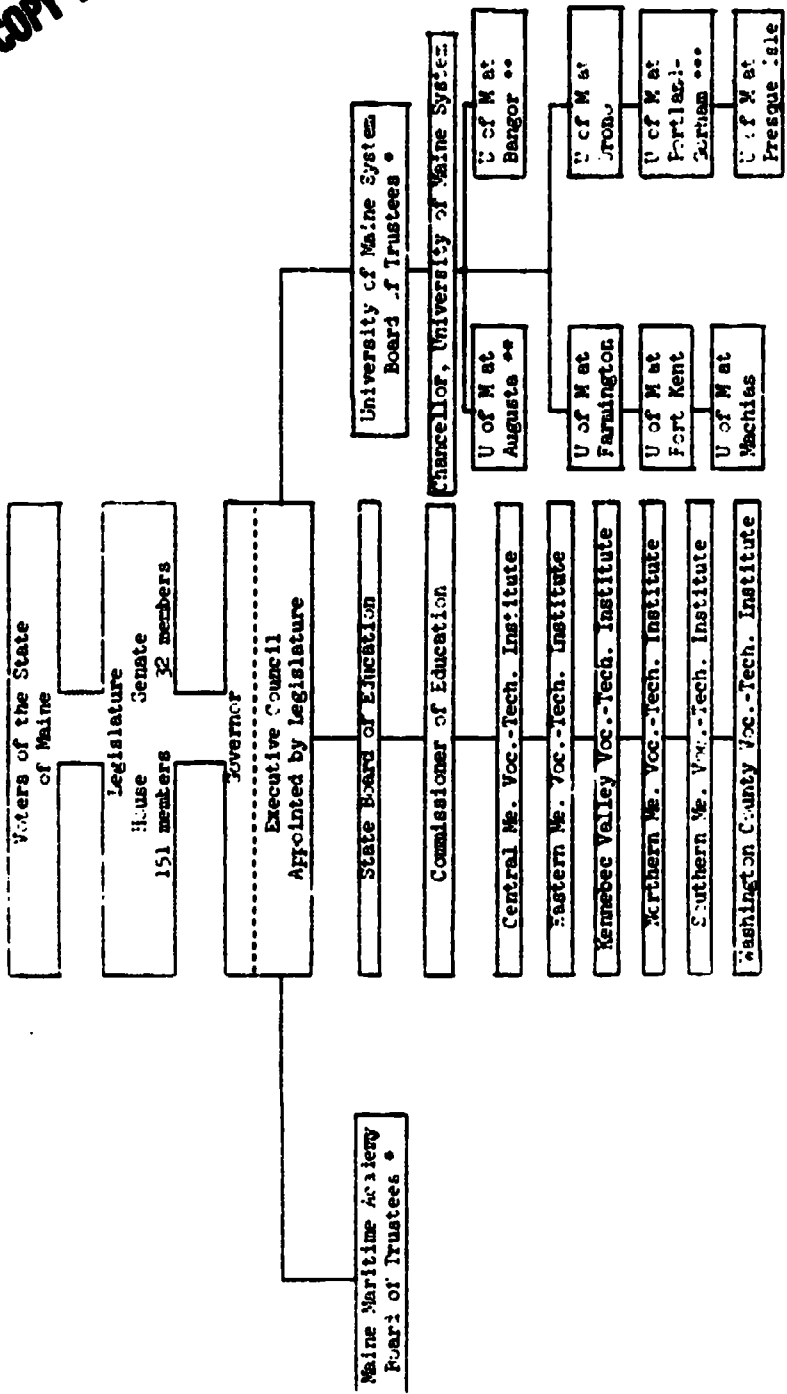

- \* Quasi-Independent Agencies
- \*\* Two-Year Institutions
- \*\*\* Includes Schools of Law

There is no central or planning agency for private institutions of higher education, and each is responsible to its own governing board.

Prepared by the Higher Education Facilities Committee  
August, 1971

Other voices raised against the proposed unified structure have been those of vocational-technical institute people. As they view the proposal, their institutions stand to lose the most, including their identity. These people are certain that under the new organization, which would convert them into community colleges, the vocational technical aspects of education would suffer too much assuming they were headed by academic presidents (13, p. 140). The problem is real and would require much additional study and understanding to avert an academic "take over" if conversion does occur. On the other hand, it will behoove planning agencies to organize programs that are as economical as possible and that, in general, avoid undue overlap and duplication. In this connection, there is a potential danger of duplication and excessive cost when states organize both community colleges and area vocational schools, both of which may be attempting similar programs. It is urgent, therefore, that planning agencies consider the role of these two types of institutions and determine whether, in the State of Maine, both are needed or whether the comprehensive community college may well be the most appropriate medium for rendering the multiplicity of programs needed in the average community.

It appears that a new concept regarding the organization of the educational system must be developed—a concept that definitely identifies the idea of an advanced community center with an extremely broad educational mission (14, p. 128).

Post-secondary occupational education in the United States is presently in its formative stages. It is still susceptible to modification and changes without the resistances that might be found in more tradition-bound programs. The systems developed by the States should be examined to find out which are superior, and why. This is not meant to imply that there should be, or is, a single, best way of organizing such programs. The possibility, however, should not be ignored (21, p. 247). For example, those states that have experienced the most success in their post-secondary programs—such as California and Florida, made community colleges an official segment of higher education, separate but on the same level as the university structure. The present trend is definitely in this direction. The Carnegie Commission on Higher Education also believes that the strong trend away from inclusion of community colleges within K-12 school districts and toward separate community college districts should be encouraged to continue (3, p. 48).

It would seem that the comprehensive community colleges are unique and could well exist as separate entities, with their own board at the same level as the Commissioner of Education and the Chancellor of the University of Maine System.

## SOURCES

1. **Carnegie Commission on Higher Education. *Less Time, More Options.*** Clark Kerr, chairman. New York: McGraw-Hill Book Co., 1971.
2. **Carnegie Commission on Higher Education. *New Students and New Places.*** New York: McGraw-Hill Book Co., 1971.
3. **Carnegie Commission on Higher Education. *The Open-Door College.*** New York: McGraw-Hill Book Co., 1970.
4. **Carnegie Commission on Higher Education. *State Officials and Higher Education.*** Prepared by Heinz Eulon and Harold Quinley. New York: McGraw-Hill Book Co., 1970.
5. **Center for Research and Development in Higher Education. *University of California, Berkeley, Vol. IV.***
6. **Cosand, Joseph P., "The Community College in 1980." *Compus 1980.*** Ed. by Alvin C. Eurich. New York: Delecarte Press, 1969.
7. **Cross, K. Patricia, "The Role of the Junior College in Providing Postsecondary Education for All." *Trends in Postsecondary Education.*** Wash., D. C.: Government Printing Office, 1970.
8. ***The First Business of Our Times.*** A report of the Advisory Commission for the Higher Education Study, State of Maine, James A. McCain, chairman. New York: Academy for Educational Development, 1971.
9. **Furniss, W. Todd, Ed.: "Educational Programs for Everybody." *Higher Education for Everybody?*** Wash., D. C.: American Council on Education, 1971.
10. **Glenny, Lyman A., and Weathersby, George B., eds. *Statewide Planning for Postsecondary Education: Issues and Design.*** Boulder, Colorado: Foundation National Center for Higher Education Management Systems at Western Interstate Commission for Higher Education, 1972.
11. ***A Guide for Planning Community Junior College Facilities.*** Prepared by D. Grant Morrison for U. S. Department of Health, Education and Welfare, Wash., D. C.: Government Printing Office, 1969.
12. ***Higher Education in the State of Maine.*** James S. Coles, chairman. Report of the Advisory Commission for the Higher Education Study to the Governor of Maine and the Legislature of the State of Maine: Moine: n.p., 1967.
13. ***Moine's Public Investment Needs of Highest Priority.*** A report submitted by ESCO Research, Inc., to the Governor of Moine. Portland, Moine: ESCO Research, Inc., 1970.
14. **Morphet, Edgar L., and Ryan, Charles O., eds. *Designing Education for the Future.*** New York: Citation Press, 1967.
15. **National Education Finance Project. *Special Study No. 6 The Community Junior College Target Population, Program Costs, and Cost Differentials.*** James L. Wattenborger, director. Gainsville, Florida: Institute of Higher Education, University of Florida, 1970.
16. **Peiffer, John. *New Look at Education.*** New York: Odyssey Press, 1968.
17. ***Progress Report of the Higher Education Planning Commission to the Chancellor of the University of Maine.*** Frank M. Coffin, chairman. University of Moine, 1969.
18. ***Report of the Chancellor's Task Force on Less-Than-Baccalaureate Degree Programs.*** Edward G. Blewett, chairman. University of Maine, 1970.
19. ***Report on Higher Education.*** Frank Newman, chairman. Washington, D. C.: Government Printing Office, 1971.
20. **Sutton, Ronnie N., *Community College or Four Year Program.*** Bulletin of the Bureau of School Service, Vol. XLIII., Lexington, Kentucky. College of Education, University of Kentucky, 1970.
21. ***Trends in Postsecondary Education.*** U. S. Department of Health, Education and Welfare. Washington, D. C.: U. S. Government Printing Office, 1970.
22. **Trent, James W. "The Decision to Go to College: An Accumulative Multivariate Process." *Trends in Postsecondary Education.*** Washington, D. C.: Government Printing Office, 1970.

## **V. POST-SECONDARY EDUCATIONAL NEEDS IN THE LEWISTON-AUBURN AREA**

There is a note of commonality regarding the future of postsecondary education in the reports published in the State of Maine that highest priority should be given to the establishment of an appropriate number of comprehensive community colleges throughout Maine. Furthermore, the concensus seems to be that these two-year institutions should offer programs combining a variety of educational and occupational options. Primary responsibilities of the community colleges would include, but not be limited to, increasing access to post high school education and offering an individualized remedial or foundation education for youths and adults.

This report is a necessary "next step" in post-secondary education planning in Maine in that it focuses upon one of the three areas singled out in earlier reports as a top priority site for the establishment of a community college. The study was commissioned and proceeded upon a firm commitment to planning in that the foundation of a successful education institution or system is sound planning.

A basic premise of this study was that any two-year college, if it is to be an effective asset to the community in which it is located, must be planned, organized and developed to meet the particular needs and interests of the local community and the people who will use it. How does this apply to the Lewiston-Auburn area?

The metropolitan Lewiston-Auburn area is the second largest population center in the state. However, post-secondary education opportunities are limited. Especially is this true for the residents of the Model Cities area. A pre-determined purpose of this project was to assess the local situation to define the characteristics — students, curriculum and facilities — of the to-be-established two-year institution in order to best serve the greatest cross-section of potential students in the area.

The following sections set forth the analyses of the data collected through surveys and appropriate reports dealing with the Lewiston-Auburn area.

### **A. High School Survey**

The high school survey indicated that a comprehensive community college would likely be well utilized by high school graduates in the Lewiston-Auburn area. The survey instrument was completed by 2,246 junior and senior year students enrolled in seven area high schools:

Edward Little High School, Auburn  
 Lewiston High School, Lewiston  
 Buckfield High School, Buckfield  
 Leavitt Area High School, Turner  
 Lisbon High School, Lisbon Falls  
 St. Dominic Regional High School, Lewiston  
 Gray New Gloucester High School, Gray

Two schools, Lake Region High School in Bridgton and Oxford Hills High School in South Paris, chose not to participate in the survey. Both schools, however, provided some data for the study.

The analysis of the data is presented below under five headings:

1. General Information
2. Interest Inventory
3. Educational Plans -- College Bound
4. Educational Plans Non-College Bound
5. Educational Occupational Interests

Further analysis of the data collected in the survey is recommended as program planning when the proposed institution actually begins.

### 1. General Information

Some researchers have shown a correlation between the educational level of parent, especially the level attained by the mother, and child. Table 5 would indicate that area children provide an ample number of potential post secondary students since 54.7 percent of the mothers have at least completed high school. (The number in the parentheses following the titles of the tables refers to the item number on the survey.)

TABLE 5: Educational level of parents (5)

LEVEL	MOTHER		FATHER	
	N	%	N	%
High School Diploma	850	38.0	635	28.9
1-3 years	449	20.0	535	24.3
1-3 yrs. high school	398	17.7	377	17.1
1-3 yrs. post secondary	242	11.2	239	10.8
College degree	94	4.2	91	4.1
Graduate degree	28	1.3	106	4.9
Unknown	173	7.8	219	9.9
TOTAL	2,234	100.2	2,202	100.0

Of particular interest to curriculum personnel associated with the proposed community college is the fact that in approximately 10 percent of the homes in the area foreign language is most often spoken. The predominant language is French.



**TABLE 6: Language spoken most often at home (4)**

LANGUAGE	N	%
English	1891	90.6
French	208	9.1
Hungarian	1	0.1
Polish	1	0.1
Spanish	1	0.1
TOTAL	2102	100.0

Educational planners will also be interested in knowing the average number of children per family as this information will certainly influence decisions pertaining to accessibility and financial aid.

**TABLE 7: Children per family (7)**

RESPONDENTS	TOTAL CHILDREN	AVERAGE PER FAMILY
2,244	11,566	5.2

## 2. Interest Inventory

The high school juniors and seniors were asked to indicate the subjects in which they were most interested. The response of the students may be of value to both high school and post-secondary educators.

**TABLE 8: Favorite high school subject (9)**

SUBJECT	N	%
Mathematics	438	19.5
Business Education	432	19.4
PE — Athletics	417	18.7
English	375	16.6
Science	362	16.1
Vocational Practical Arts	330	14.8
Social Science	246	10.8
Music Fine Arts	173	7.7
Home Economics	159	7.1
Health Science	125	5.6
Foreign Language	123	5.5
Agricultural Science	107	4.7
Other	6	0.3

A greater number of responses than students occurred due to the multiplicity of answers permitted. The total response to each subject area was divided by the number who completed the survey. This technique results in a more accurate indicator of student preference. The percentage, however, totals more than 100.

The students also indicated career preference. The choice was to be restricted to that career in which the student felt he had the necessary ability and a good chance to succeed.

**TABLE 9: Career Choice (10)**

CLASSIFICATION	N	%
Professional Technical	611	29.0
Clerical Sales	485	23.0
Construction	211	9.8
Service	191	9.1
Agriculture Fishery	190	9.0
Machinist Trades	142	6.7
Bench work Repair	51	2.4
Processing	40	1.9
Other	198	9.4
<b>TOTAL</b>	<b>2,119</b>	<b>100.3</b>

### 3. Educational Plans — College Bound

Plans for post-secondary education tend to reflect the high aspirations of students and their parents. Even in Maine, a state which sends a relatively low percentage of its students to post-secondary institutions, the aspiration level is high. Indeed, the data indicated that 92.3 percent of the students' parents wanted their children to continue their education beyond high school. Perhaps the students are more realistic in that 69 percent indicated a desire to continue their education beyond high school.

**TABLE 10: Parental view of post-secondary education (18)**

PARENTAL VIEW	N	%
Wants child to attend	1518	69.0
Insists that child attend	512	23.2
No concern	130	5.8
Opposed to idea	23	1.0
Forbids attending	2	0.1
Other	20	2.0
<b>TOTAL</b>	<b>2,205</b>	<b>101.1</b>

**TABLE 11: Intention of students to continue education beyond high school (11)**

INTENTION	N	%
Yes	1486	69.0
No	662	31.0
<b>TOTAL</b>	<b>2,148</b>	<b>100.0</b>

Approximately the same number, if the "other" item is removed, of students who indicated a desire to continue their education beyond high school checked the type of institution they would prefer to attend. The types of institutions listed in the survey were those normally considered as available to students in the Lewiston-Auburn area. Therefore, the two-year community college was not included in the list.

**TABLE 12: Type of institution planning to attend (13)**

TYPE OF INSTITUTION	N	%
University of Maine (any campus)	359	24.1
Vocational/Technical Institution	345	23.2
Public Institution out-of-state	132	8.9
Private Institution in Maine	107	7.2
Private Institution out-of-state	105	7.2
Other	117	7.8
Uncertain	412	27.8
<b>TOTAL</b>	<b>1,577</b>	<b>100.0</b>

The next item in the survey was directed at the 1,486 students who desired to continue their education (table 11), and who had indicated the type of institution they planned to attend (table 12).

**TABLE 13: Prefer to attend a two-year, low cost community college if available (14)**

PREFERENCE	N	%
Yes	683	45.5
No	803	54.5
<b>TOTAL</b>	<b>1,486</b>	<b>100.0</b>

The response recorded in Table 13 indicated that a significant number of students intending to attend a more conventional type institution could be diverted to attend a local community college. One result to be expected from such a diversion may be an easing of tension due to rising student population on some campuses in the state.

Perhaps one reason for the switch to the local, low cost community college was in view of financial considerations. Less than 50 percent of the students indicated that they would continue their education with family support. Of course, even this percentage probably includes students who will receive only partial support from family.

**TABLE 14: Plans to finance post-secondary education (12)**

PLAN	N	%
Part-time work	767	51.6
Family support	693	46.6
Loans	318	21.3
Self-support	275	18.5
Scholarships	251	16.9
Other	24	0.9
Uncertain	319	21.3
<b>TOTAL</b>	<b>2,647</b>	<b>—</b>

#### 4. Educational Plans – Non-College Bound

A total of 662 students indicated no intention to continue their education (Table 11). These students checked an average of two reasons each for their decision.

**TABLE 15: Reasons for not planning to continue education (15)**

REASON	N	%
Money – want to work	295	44.5
Tired of school	228	34.0
Grades too low	215	32.5
Cannot afford	179	27.0
Plan to marry	163	25.0
Entering military	143	21.6
Do not need college education	97	14.6
Parents opposed	12	1.8
Other	24	3.6
<b>TOTAL</b>	<b>1,356</b>	<b>—</b>

The financial question seems to have played a major role in student planning. The same may be said regarding the availability, in terms of location, and the type of the institution. The effect of these factors was demonstrated in the survey and reported in Tables 16 and 17.

**TABLE 16: Influence on non-college bound students of availability of a low-cost, local community college (16)**

<b>CHANGE MIND ABOUT CONTINUING EDUCATION</b>	<b>N</b>	<b>%</b>
Yes	258	39.0
No	394	61.0
<b>TOTAL</b>	<b>652</b>	<b>100.0</b>

**TABLE 17: Influence on non-college bound students of financial aid and local community college (12)**

<b>CHANGE MIND ABOUT CONTINUING EDUCATION</b>	<b>N</b>	<b>%</b>
Yes	284	41.5
No	366	58.5
<b>TOTAL</b>	<b>650</b>	<b>100.0</b>

It would seem that with the removal of such barriers as financial and distance to post-secondary education, more students who normally do not plan to continue their education beyond high school could plan to do so.

Perhaps academic rank, as estimated by the student, also stands as a barrier to many students in the Lewiston-Auburn area. Only 653 students ranked themselves in the upper third of their class. The other students probably considered admission and retention problems as they made plans either for or against continuing their education. The typical community college is dramatically student oriented and operates with an open door policy. Ideally, special programs are designed and implemented to help students overcome weaknesses so that the possibility of success is maximized for each student.

**TABLE 18: Estimate of academic rank in class (8)**

<b>RANK</b>	<b>N</b>	<b>%</b>
Upper third	653	29.8
Middle third	1289	58.8
Lower third	240	11.4
<b>TOTAL</b>	<b>2,182</b>	<b>100.0</b>

### **5. Educational Occupational Interests**

The survey presented the problem to the students of selecting either a two-year or a four-year post-secondary program. Of those responding, 57.8 percent stated a preference for a two-year program.

**TABLE 19: Student selection between two- and four-year programs (A-B)**

PROGRAM	N	%
Two-year	1180	57.8
Four-year	840	42.2
TOTAL	2020	100.0

This response seems to correlate closely with the actual needs in Maine. The Coles' Commission Report stated that only 7 percent of all the jobs in the state require college preparation while more than 50 percent of the jobs are in the trade, technical, and distributive fields and require less-than-baccalaureate preparation.

The recent report, **Higher Education Planning for Maine**, (p. 16) stated that over the years from 70 to 75 percent of the University of Maine at Orono non-teaching graduates have been employed out-of-state. There are not enough jobs in Maine to allow the state to hold its young.

Add to this the fact that as late as 1970, only 6.1 of the University of Maine student body was enrolled in two-year programs and the question of relevance begins to emerge.

The students also ranked by degree of interest ten different program categories. Each category was defined in the survey by listing several sample careers within the category.

**TABLE 20:**

**Student selection of two-year programs ranked by degree of interest (A)**

PROGRAM CATEGORY	N	DEGREE OF INTEREST
Social Services	847	1.85
Aviation, Oceanography, Cosmetology, etc.	842	1.91
Business Administration	2,897	1.95
Agriculture Forestry	778	1.95
Environmental Studies	762	1.96
Health Services	937	1.96
Building Trades	1,076	1.98
Food Services	472	2.01
Engineering Mechanical	2,575	2.06
Liberal Arts	375	2.33

Each program category in Table 20 contained from three to twenty specific areas of study. Students were encouraged to rate on a 1 to 3 scale up to three areas in each category. The number 1 indicated the highest degree of interest. Therefore, the lower the figure in the right hand column, the higher the degree of interest.

The data also provided for a ranking of program categories on the basis of popularity among the students. The most popular category was Business Administration. A total of 723 students responded to this category. The least popular category was Building Trades to which 322 students responded.

**TABLE 21:**  
**Program categories ranked by popularity among students (based on total response to category)**

PROGRAM CATEGORY	NUMBER OF STUDENTS
1. Business Administration	723
2. Environmental Studies	571
3. Health Services	441
4. Aviation, Oceanography, Cosmetology, etc.	423
5. Social Services	402
6. Liberal Arts	375
7. Engineering Mechanical	369
8. Agriculture Forestry	368
9. Food Services	354
10. Building Trades	322

The program categories were further defined by a total of 78 specific subject areas. The same degree of interest scale, 1 to 3, applied. Table 22 presents the top 13 areas giving both rank, subject area, number, and degree of interest. Attention should be given to the list as the curricula for the proposed community college are developed.

**TABLE 22:**  
**Student selection of specific subject areas ranked by degree of interest (A)**

SUBJECT AREA	N	DEGREE OF INTEREST
1. Criminal Justice	124	1.26
2. Executive Secretarial Science	328	1.40
3. Secretarial Science	266	1.52
4. Forest Ranger Aide	277	1.64
5. Aviation	185	1.66
6. Management	243	1.67
7. Art	179	1.70
8. Animal Medical Technology	155	1.70
9. Building Construction Technology	144	1.70
10. Nursing	146	1.73
11. Mental Health Workers	164	1.77
12. Forest Management	217	1.78
13. Automotive Technology	192	1.78

## **6. Barriers to Post-Secondary Education**

In alleviating the distance barrier by creating geographic accessibility; in developing low cost educational services to prevent a financial barrier; in resolving the problem of the socioeconomic hierarchy barrier through a diversified program, in removing the admission problem through an open door policy, the mission of the community college becomes evident – equal educational opportunity for everyone.

There is a barrier related to two-year programs which should be recognized and resolved. There is a stigma in peoples' minds regarding two-year institutions which focuses upon vocational-technical programs. A hierarchy of institutions and a hierarchy of programs within institutions do exist. Dr. William E. Robinson, Dean, Adult Education and Community Services, University of Maine at Augusta, stated that "as long as the stigma of vocational education remains, great expansion in enrollment is not expected to take place. Perhaps changing the names of the Vo-Tech Institutes to Community Colleges might help remove this stigma." (Supplement in Freeman report, p. 21).

The point is that simply constructing buildings and staffing them is not enough. Making the institutions accessible and inexpensive may not produce the desired result. An appropriate public relations campaign which may well include changing the names of the institutions could be necessary in order to remove persistent barriers to post-secondary education in Maine.

## **7. Selected Characteristics of Students**

The value of a system of comprehensive community colleges within a state may be seen in part at least, by studying the characteristics of the students who attend these institutions. Cross presented a table in which the results of a study of students in 63 comprehensive community colleges were tabulated. The table is reproduced here since it is assumed that the characteristics of the students who enroll in Maine's comprehensive community colleges, once they are operational, will be similar to those of students elsewhere.



TABLE 23

**SELECTED CHARACTERISTICS OF STUDENTS ENROLLED  
IN THREE CURRICULUMS IN 63 COMPREHENSIVE COMMUNITY  
COLLEGES, IN PERCENTAGES<sup>a</sup>**

Characteristics	College Parallel	Tech- nical	Voca- tional
<b>Sex</b>			
Male	60	61	58
Female	40	39	42
<b>Father's occupation</b>			
Unskilled or semiskilled	18	26	35
White collar	46	35	25
<b>Parental income</b>			
Less than \$6,000	14	14	24
More than \$10,000	36	28	21
<b>Father's formal education</b>			
Less than high school graduation	27	34	50
Some college or more	31	20	14
<b>Race</b>			
Caucasian	91	79	70
Negro	5	7	14
Oriental	1	7	7
Other	1	4	6
<b>Main reason for attending this institution</b>			
Inexpensive	25	18	13
Close to home	28	22	19
Strength of major	8	24	32
<b>Educational aspirations</b>			
One-year program	2	3	29
Two-year special training	10	12	6
Bachelor's degree	38	19	8
M.A. or higher	17	6	3
<b>Work wanted after finish education</b>			
Plans vague	28	20	11
Have good idea	47	48	48
Know exactly	19	23	30
<b>Object of education</b>			
Mostly or entirely general education	60	34	21
Mostly or entirely job training	31	51	64
<b>High school courses waste of time</b>			
Disagree	51	47	44
Agree	42	44	45

<sup>a</sup>Only selected alternatives are given and categories have been combined to present a succinct summary of data.

Source: Cross, *Postsecondary Education for All*, p. 191. Comparative Guidance and Placement Program, 1969.

## B. The Industrial Survey

The basic purpose of the industrial survey was to gain data which would permit making assumptions about present and further business and industrial employee needs in the immediate Lewiston-Auburn area. A group of industries employing a minimum of fifty workers were solicited for the survey. A total of twenty-three companies responded by returning completed forms.

Table 22 shows that approximately 4,000 production workers were included in the survey. In 1970, a total of 13,450 production workers were reported in Androscoggin County, the immediate area to be served by the proposed post-secondary institution (1, p. 7.5). This would indicate that approximately one-third of the county's manufacturing production workers are employed by one of the twenty-three responding companies.

TABLE 24:

### Selected job categories -- skill upgrading and projected openings by 1975

Job Category:	Approx. No. Now Employed	No. Need- ing Skill Upgrading	Positions Open by 1975
Secretarial Clerical	410	23	479
Sales Personnel	147	14	41
Line Operation	3,971	344	870
Maintenance	122	5	35
Central Administrative Staff	184		27
<b>TOTALS</b>	<b>4,834</b>	<b>386</b>	<b>1,452</b>

Table 25 represents an adjustment of the survey totals. The adjustment was made on the assumption that the one-third figure on production workers would also apply to the other categories of employees listed in the instrument.

TABLE 25:

### Selected job categories -- skill upgrading and projected openings by 1975 (adjusted)

Job Category:	Approx. No. Now Employed Adjusted	No. Need- ing Skill Upgrading Adjusted	Positions Open by 1975 Adjusted
Secretarial Clerical	1,230	69	1,437
Sales Personnel	441	42	123
Line Operation	11,913	1,032	2,610
Maintenance	366	90	105
Central Administrative Staff	552	162	81
<b>TOTALS</b>	<b>14,502</b>	<b>1,395</b>	<b>4,356</b>

It should be emphasized that the figures presented are only indicators of actual totals. Limitations of time and money would not permit statistically sound surveys at this point. It should also be noted that business-industries represent only one category of employment in the country. The business-industry category was selected for the survey because a significant percentage of Model Cities employed persons work as manufacturing production personnel (2, p. 3, 51).

Based upon the survey figures, approximately ten percent (1,395) of those presently employed in business-industry need their skills upgraded. An additional 4,356 employees will be needed between 1972 and 1975 to fill anticipated vacancies and new positions. Of course, much, perhaps most, of the upgrading can be accomplished on the job. By the same token, perhaps most of the vacancies and new positions can be filled by persons who have no training beyond high school. However, it may be assumed that these approximate figures do reveal that an important service could be rendered to both employees and employers by a comprehensive community college in tune with community needs. This report maintains that Model Cities residents would be among those who stand to gain most from the proposed community college.

Several of the instruments which were returned by companies contained suggestions for courses which would be helpful to their employees. The suggestions included:

1. Secretarial training: typing, business math, spelling, penmanship, business English and French, and general office procedures.
2. Management and operations: shop level management, plant level management and administration, computer programming and use, advanced accounting, and salesmanship.
3. Specialized skills and maintenance: general and mechanical maintenance including refrigeration, steam fitting and oil burner service, machine shop operators, basic metallurgy, and metal casting.
4. General: economics and the free enterprise system, cultural enrichment.

It would seem reasonable to conclude that a comprehensive community college working in concert with employer and employee needs could render a most significant contribution to the area and to Maine. It is also reasonable to assume that such an institution, responsive to the real needs of those it serves, would become an effective component in attracting a variety of new industries into the area.

### C. The Model Cities Survey

The Model Cities survey was designed to extract data which might assist decision makers in developing curricula and programs which would maximize the service of the proposed comprehensive community college to the residents of the Lewiston Model Cities area. A total of 151 surveys was returned and these included information on approximately 650 youths and adults. In addition to data collected from this survey, pertinent information was taken from **The Lewiston Model Neighborhood Area: A Comprehensive Community Planning Survey** which was published in 1970. That survey was quite extensive and included more than twenty percent of the 4,680 households in the area.

The surveys revealed that a predominance of those employed, men, women, and youths, fall into the laborer classification. In fact, the project survey reflected that 79 percent of the working fathers stated that they held a working-man's job." The Model Cities survey revealed that 76 percent of the working men fell into this category. Seventy percent of these men work in Lewiston, an additional 15 percent work in Auburn.

Other jobs held by the working men in the Model Cities area included the following:

TABLE 26:

#### Jobs other than "working men's jobs" held by Model Cities males

JOB	%
Foreman's job	4
White collar job	7.3
Manager's job	2
Professional's job	5.4
Self-employed	2.3
Other	2.6
TOTAL	23.6

The "skill level" of the working men was also tabulated on the number responding to the item.

TABLE 27:

#### Skill level of working males in Model Cities

SKILL LEVEL	N	%
Highly skilled	140	31.1
Somewhat skilled	240	53.3
Unskilled	70	15.5
TOTAL	450	99.9

Another survey result significant to this study regards attitude of the worker toward his present job.

**TABLE 28:****Attitude toward job of employed persons in Model Cities**

ATTITUDE TOWARD JOB	N	%
Like it very much	313	54.2
Like it fairly well	197	34.1
Dislike it somewhat	34	5.9
Dislike it very much	34	5.9
<b>TOTAL</b>	<b>578</b>	<b>100.1</b>

The residents, men, women, and youths, listed several non-occupational skills which they used in household duties or for pleasure. Included were such items as cooking, sewing, child care, painting, woodworking, leather working, and ceramics.

The residents of Model Cities saw higher wages and more jobs as the two most important factors needed to improve the living conditions in the area.

**TABLE 29:****Factors needed to improve living conditions in Model Cities**

ECONOMIC IMPROVEMENTS	N	%
Higher wages	361	54.5
More jobs and industries	176	26.6
Other	125	18.9
<b>TOTAL</b>	<b>662</b>	<b>100.0</b>

The chief wage earner in each household was asked to classify his weekly salary.

**TABLE 30:****Salaries of Model Cities Principal Wage Earners**

SALARY IN \$	N	%
Up to 35	144	22.0
36 to 50	37	5.7
51 to 65	57	8.7
66 to 80	171	26.1
81 to 95	87	13.3
96 to 110	63	9.6
111 to 125	37	5.7
126 to 140	24	3.7
141 or more	34	5.2
<b>TOTAL</b>	<b>654</b>	<b>100.0</b>

The above table indicates that approximately 76 percent of the principal wage earners in the Model Cities area earn less than \$96.00 weekly.

The problem of recreation was reflected by the respondents and tabulated for both adults and youths.

**TABLE 31:**

<b>Recreation of residents of Model Cities — Adults</b>		
<b>ADULT RECREATION</b>	<b>N</b>	<b>%</b>
Nothing — sit around	58	6.2
TV, radio	244	26.2
Read	31	3.3
Sports, games, camp, travel	558	59.9
Other	39	4.2
<b>TOTAL</b>	<b>930</b>	<b>99.8</b>

**TABLE 32:**

<b>Recreation of residents of Model Cities — Youths</b>		
<b>YOUTH RECREATION</b>	<b>N</b>	<b>%</b>
Nothing	4	2.4
TV, radio	5	3.0
Read	117	70.1
Sports, games, camp, travel	41	24.5
<b>TOTAL</b>	<b>167</b>	<b>100.0</b>

**TABLE 33:**

**Degree of satisfaction with recreation provided in Model Cities**

<b>SATISFACTION</b>	<b>ADULT</b>		<b>YOUTH</b>	
	<b>N</b>	<b>%</b>	<b>N</b>	<b>%</b>
Very satisfied	229	30.0	100	15.0
Fairly satisfied	304	39.8	225	33.7
Not too satisfied	140	18.4	190	28.4
Not satisfied	90	11.8	153	22.9
<b>TOTAL</b>	<b>763</b>	<b>100.0</b>	<b>668</b>	<b>100.0</b>

The percentage of Model Cities residents who were reared in a bilingual home was also considered important to this study.

**TABLE 34:**

**Residents of Model Cities reared in bilingual homes**

<b>BILINGUAL PARENT(S)</b>	<b>N</b>	<b>%</b>
Yes	803	84.7
No	144	15.2
<b>TOTAL</b>	<b>947</b>	<b>99.9</b>

In 97.8 percent of the bilingual homes, the foreign language was French.

One of the most interesting categories of the surveys concerned education. The differences are striking between the figures revealing the percentage of persons actually attending college in Lewiston and those considered as future college students in the family.

**TABLE 35:**

<b>Model Cities students Attending College in Lewiston</b>		
<b>ATTENDING IN LEWISTON</b>	<b>N</b>	<b>%</b>
Bates College	0	---
Bliss College	2	0.2
No one in local colleges	953	99.8
<b>TOTAL</b>	<b>955</b>	<b>100.0</b>

**TABLE 36:**

<b>Model Cities high school students planning to attend college</b>		
<b>COLLEGE PLANS</b>	<b>N</b>	<b>%</b>
Yes	121	29.4
No	168	40.8
Uncertain	123	29.9
<b>TOTAL</b>	<b>412</b>	<b>100.1</b>

Special interest was shown in free occupational training courses designed to upgrade skills in one's present job skills or to train the worker for another job.

**TABLE 37:**

<b>Model Cities workers desiring additional training</b>		
<b>WANTS TRAINING</b>	<b>N</b>	<b>%</b>
Yes	269	28.9
No	662	71.1
<b>TOTAL</b>	<b>931</b>	<b>100.0</b>

Job training was specified by those desiring additional training.

**TABLE 38:**

<b>Type of job training desired</b>		
<b>TYPE OF TRAINING</b>	<b>N</b>	<b>%</b>
Electronics	29	15.2
Carpentry	10	5.2
Shoe shop work	9	4.7
Office work	63	33.0
Other	80	41.9
<b>TOTAL</b>	<b>191</b>	<b>100.0</b>

The data contained in the above tables should be carefully considered as the mission, objectives and programs of the proposed comprehensive community college are developed. It is assumed that the institution would be designed to meet the specific and particular needs of Model Cities residents, as well as the needs of the residents of the area at large. Such con-

sideration will require a recognition of the type of jobs held by the residents of the area, the skill level of those jobs, the attitude the workers hold toward their jobs and their wages, and the type of additional job training desired.

A comprehensive community college, however, should be concerned with matters beyond job training. It should provide avenues for increasing recreational interests and opportunities for upgrading the cultural background of the people as well. Of course, the central mission of a community college should include the development of a strong academic program in order to maximize equalization of post-secondary educational opportunities for citizens of Maine.

#### **D. Post-secondary opportunities in the Lewiston-Auburn area**

The post-secondary educational training opportunities in Lewiston-Auburn are limited to five private schools, two public institutions, and adult education courses sponsored by the high schools.

##### **Private College in Lewiston-Auburn**

1. **Bates** is the largest and only four-year college in the area. It has an enrollment of 1,239 students of which approximately 2% come from Lewiston-Auburn and 11% from the whole state. It was founded in 1864, and still is a relatively small, coeducational, liberal arts college, without fraternities or sororities. Bates has limited its admission and grown slowly. The Bates trustees have planned a gradual enrollment increase to 1,400 students over the next several years. Twenty-five to thirty states and over twenty foreign countries are represented in the student body. Bates is fully approved by all appropriate accrediting agencies and learned societies. The campus is built on 100 acres. Tuition excluding room and board is \$2,375.

2. **Bliss College**, founded in 1898, is a coeducational junior college offering Associate Degree transfer programs in Arts and Sciences and Business Administrative and Terminal Programs in Commercial Art and Secretarial Sciences. The college has a 1/4 acre campus composed of three houses of which one is used for a student dorm. Its enrollment approaches 100 students. Tuition including room and board is \$1,150 per year. It does not require College Boards as an entrance requirement. Students may enter any of the Divisions, no matter what program they may be in in high school. Most of the students come from the Lewiston-Auburn area.

3. **Auburn Maine School of Commerce**, founded in 1916, is a small business school with a 20 acre campus. Its courses are two years in length designed to train a two-year terminal student. An active lifetime placement program is offered by the school. Its courses are diploma courses, and the intent of the curriculum is to make each student employable. Present en-



rollment is approximately 150 students, of which 99 percent are from Maine and 60 percent from the Lewiston-Auburn area. Future plans for the school call for an upper limit of 200 students. The campus is spacious and pleasant. It classifies itself in the category of vocational education with the intent to train excellent accounting, secretarial, and business administration candidates. Also, the school offers a single year secretarial finishing course which provides a vigorous program for superior high school graduates. Tuition excluding room and board is \$930 per year.

4. **Hanson's Barber School** is located in Lewiston. It has facilities to train forty barbers. Presently, the enrollment is twenty. Approximately 90 percent of its students are from Maine. The student age range is from seventeen to sixty-six, but most students are in the age range of seventeen to twenty-five. Its tuition is \$600 plus supplies for nine months.

5. **Mr. Bernard's School of Hair Fashion** is located in Lewiston. The primary aim of the school is to develop a person who will succeed in the field of Cosmetology by becoming a Professional Cosmetologist. There are complete housing accommodations. Enrollment varies from eighty to ninety students. Tuition excluding room and board is \$1,200 plus supplies for nine months. Approximately 66 percent of the students come from the Lewiston Auburn area; only 5 percent of the students come from out-of-state.

## Public Schools

1. **Central Moine Vocational Technical Institute** was created by an Act of the 101st Legislature in 1963; the first classes were held in September, 1964. It is located on the shores of Lake Auburn, about three miles from the city of Auburn. Its 150 acre campus provides a beautiful setting for this educational institution with its new administration-classroom building and dormitory. Presently a wing of classrooms and or laboratories is being constructed to house a great variety of new proposed programs. The curriculum at this time includes evening courses in two year offerings in the vocational and technical areas and a twelve month course in practical nursing. The campus size and location is most ideal for the Lewiston-Auburn area especially with the third bridge that is presently being built. The age range of the present 290 full time students is eighteen to forty years. Approximately 50 percent of the students come from the Lewiston-Auburn area. There is also a large group of adult part time students. Maine resident tuition is \$135.50 each semester.

2. **University of Maine, Continuing Education Division, Lewiston-Auburn.** CED maintains an office on the CMVTI campus and conducts its classes in available space at CMVTI, local high schools, and junior high schools. They work with a large age range of students from eighteen to seventy years, and according to a 1969 survey, the average age was 30

years. The approximate enrollment figures are 500 per semester and 150 in the summer. At least 75 percent of the students come from the Lewiston-Auburn area. These students are classified as part-time students. Tuition is \$25 per credit with a maximum of \$200 per semester.

There are a variety of courses offered to adults in the area high schools. These courses are non-credit. They range from adult basic education courses to vocational and avocational courses.

TABLE 39:

**Student Population Characteristics of Lewiston-Auburn  
Post-Secondary Institutions**

	Approximate Enrollment	% of Moine Students	% of L. & A. Students	Student Age Range
Auburn Maine School of Commerce	140-150	99%	60%	17-55
Bates College (4 yr.)	1,239	11%	2%	
Bliss College	100	90%	70%	18-25
CMVTI	290 DT	97%	50%	18-40
	250 NT	97%	50%	18-40
Hanson's Barber School	20-40	90%	20%	17-66
Mr. Bernard's School of Hair Fashion	85 Sept.-Apr. 40 Other	95%	66%	18-60
University of Maine, C.E.D.	500 es. sem. 150 summer	99%	75%	18-70

Source: Estimates by professional staff of each institution.

**Curriculum Assessment**

The purpose of the curriculum study was to determine the present post secondary offerings in the Lewiston-Auburn area. A Consolidated Course Matrix (figure 7), with a course matrix key Appendix was designed to show course offerings at each institution whether the institution was private or public and the amount of tuition charged. The course matrix key was composed of nineteen major program curriculum categories containing a listing of specific courses for each category. The courses listed within the major categories were courses most often found in less-than-baccalaureate level training of education institutions of the United States.

Although the chart speaks for itself, it is important to note some of those programs not covered in the current offerings at the post-secondary level that students indicated an interest in as shown in Table 22.

**Criminal Justice**  
**Forest Ranger Aid**  
**Aviation**  
**Art (very limited)**  
**Animal Medical Technology**  
**Mental Health Workers**  
**Forest Management**

When the actual development of programs for the proposed community college begins, the curriculum matrix should be helpful, if updated.

**BEST COPY AVAILABLE**

**APPENDIX B**  
**LIST OF CONTRIBUTORS**  
 to  
**Master Education Evaluation Program Project**  
 Project on Early Educational Experiences

Adaptation of the Program	John H. Biggs	University of Wisconsin	Mr. Howard L. Smith	University of Wisconsin	Public Affairs
Adaptation of the Program	John H. Biggs	University of Wisconsin	Mr. Howard L. Smith	University of Wisconsin	Public Affairs
Adaptation of the Program	John H. Biggs	University of Wisconsin	Mr. Howard L. Smith	University of Wisconsin	Public Affairs
Adaptation of the Program	John H. Biggs	University of Wisconsin	Mr. Howard L. Smith	University of Wisconsin	Public Affairs
Adaptation of the Program	John H. Biggs	University of Wisconsin	Mr. Howard L. Smith	University of Wisconsin	Public Affairs
Adaptation of the Program	John H. Biggs	University of Wisconsin	Mr. Howard L. Smith	University of Wisconsin	Public Affairs
Adaptation of the Program	John H. Biggs	University of Wisconsin	Mr. Howard L. Smith	University of Wisconsin	Public Affairs
Adaptation of the Program	John H. Biggs	University of Wisconsin	Mr. Howard L. Smith	University of Wisconsin	Public Affairs
Adaptation of the Program	John H. Biggs	University of Wisconsin	Mr. Howard L. Smith	University of Wisconsin	Public Affairs
Adaptation of the Program	John H. Biggs	University of Wisconsin	Mr. Howard L. Smith	University of Wisconsin	Public Affairs



CURRICULUM CATEGORIES	Authors Name in Book of Contents	Public College	Public College	Coastal Marine Vocational Technical Institute	Number Number School	Mr. Bernard's School of Blue Puddle	University of Maine (Continuing Education)
	COURSES OFFERED	COURSES OFFERED	COURSES OFFERED	COURSES OFFERED	COURSES OFFERED	COURSES OFFERED	COURSES OFFERED
Business	Basic Accounting Accounting Accounting Intermediate Accounting Federal Income Taxation Business Law Principles English Fundamentals Data Processing Fundamentals Principles of Self-Management Career Development Public Speaking	Introduction to Accounting Business Organization & Finance Money and Monetary Policy	Business Law I & II Federal Taxation I & II Elementary and Intermediate Accounting I & II Economics I & II				Business Finance, Insurance Law Principles of A. Real Estate Practice Principles of Economics
Communications	Written Communication						Communications Difficulties in Speech & Hearing Disorders
Child Development and Nursery Education	Child & Adolescent Development						
Hotel, Motel and Restaurant Management							
Marketing and Advertising	Marketing		Introductory Marketing Principles of Retailing I				Marketing
Mathematics	Retail Merchandising			Auto Mechanics & Associated Technology			
Health and Related Occupations	Physical Education for men & women Materials & Methods in Coaching Athlete Terms Principles & Physiology of Physical Ed Psychology 12 courses Sociology 13 courses Anthropology 5 courses			Practical Nursing, Basic Nursing Material & Child Nursery Adult Nursing, Nursing Nutrition Nursing Personal & Vocational Rehabilitation			Anthropology Sociology Psychology Philosophy & Modern Life, Nutrition of the Family Family Relationships

CURRICULUM CATEGORIES	Auburn Maine School of Commerce	Dates of Offerings	Central Maine Vocational Technical Institute	Hansen's Barber School	Mr. Bernard's School of Hair Fashion	University of Maine Continuing Education
Religion		Religious Courses				
Science		<p>BIOL 21 courses                      Chemistry 16 courses                      Geology 16 courses                      Physics 16 courses                      Astronomy 1 course                      Government Political Science Courses</p>				
Secretarial and Clerical	<p>Business Mathematics                      Typewriting, Shorthand &amp; Transcription                      Office Procedures                      Medical Terminology                      Typing</p>	<p>Elementary Typing                      Shorthand &amp; Transcription</p>	<p>Business Mathematics                      Business Mathematics - Legal                      Medical &amp; Insurance                      Office Procedures I &amp; II                      Dictation &amp; Transcription                      I &amp; II                      Legal &amp; Medical Terminology                      Elementary &amp; Intermediate                      Shorthand &amp; Typewriting                      Medical &amp; Legal Terms &amp; Terminology (Clinical Pathology)</p>			<p>Highlights in Principles of Government Political Science</p>
Teaching		<p>Elementary &amp; Training Courses</p>				<p>Teaching Social Studies                      Growth &amp; Learning Process                      Teaching Physical Ed in Elementary Teaching                      Science Science Education                      Group Dynamics Evaluation                      &amp; Measurement Psychology                      Educational Technology for Elementary Teachers                      Children Maine School Law</p>
Parenting and Conversation						



Mr. Bernard S. Barber  
 University of Maine  
 C. Olin College of Education  
 Bangor, Maine 04417

Mr. Barber and a Staff  
 of Hair Barber

Central Maine  
 Technical Institute  
 Bangor

Bangor, Maine

Bangor, Maine

Bangor, Maine

**COURSES OFFERED**

**COURSES OFFERED**

**COURSES OFFERED**

**COURSES OFFERED**

**COURSES OFFERED**

**COURSES OFFERED**

Headmaster, Technical Institute  
 Bangor, Maine  
 Bangor, Maine  
 Bangor, Maine

**COURSES**  
 Barbering  
 Hygiene, Sanitation, Shaving  
 Sterilization, Anatomy &  
 Physiology, Haircutting,  
 Facial & Nail Treatment,  
 Shampooing, Manicuring,  
 Waxing, Waxing, Hairdressing,  
 Barbering Management

Building Construction &  
 Associated Technology  
 Architectural & Civil  
 Engineering Technology  
 Machine Learning &  
 Mechanical Technology  
 Industrial Technology &  
 Associated Technology  
 Machine Tool & Mechanical  
 Technology, Process  
 Control & Instrumentation  
 Technology, Mathematics  
 & Science courses

Wood & Paper Products  
 Technology  
 Paper Technology  
 Textile Technology  
 Printing Technology  
 Metal Technology  
 Machine Tools  
 Machine Tools  
 Machine Tools

Trade - Occupational

Technical - Liberal Arts

**NOTE**  
 Tuition including room and board  
 Kannon Barber School and Mr. Bernard S. Barber - Technical Institute  
 Bates College only the number 4 is correct since fields of study are listed



## **E. Input From Community Sources**

The Carnegie Commission on Higher Education believes that since local community colleges should gear their occupational programs to local, state, and national labor market trends, local people should be involved in development of these colleges. To function effectively in the community, it is imperative for the community college to have the local support of its citizens.

Then, too, since the proposed community college would affect the lives of so many people in the Lewiston-Auburn area, input into this planning study was sought from a variety of sources in addition to the surveys conducted. These additional sources included, but were not limited to, the following:

1. The Advisory Council
2. Personal interviews
3. Statement by concerned persons
4. High School data not included in the survey
5. Tech Memo
6. Local newspaper articles

A resume of this data is presented in this section. The documents from which the following is taken are in the appendix.

### **1. Advisory Council and Personal Interviews**

The Advisory Council met as a group and individually with the Director and reviewed the project progress, served as a sounding board for problems that developed, and provided direction as the need arose.

- a. As a result of the council's suggestion, Congressmen William D. Hathaway, Peter N. Kyros and Senators Margaret Chase Smith and Edmund S. Muskie were contacted by letter in which they were made aware of the project and asked if they might be of any assistance. Each of them responded with material and names of other people that could be a source of help.
- b. The Model Cities representatives were very helpful in showing the needs of this neighborhood from their individual experiences.
- c. The University and CMVTI representatives cooperated by clarifying the role of each as to post-secondary education in the area. CMVTI opened their facilities to the council for meetings.
- d. The members at large from Lewiston and Auburn related the history of the Community College movement in the area.
- e. The Bliss College representatives familiarized the Director with the position of Bliss in regards to having a public community college in the area.
- f. While meeting with a Model Cities representative the following statements were recorded:



- Lewiston needs employment and housing.
- Low income people need to learn how to work, manage money, take care of family needs.
- Low income people need to feel they are of more worth by being treated as human beings.
- They have been fired, evicted, stamped on etc., and didn't like it but didn't know what to do.
- Low income people have creative and original ideas.
- A job is not enough; they need counseling.
- Counselors should go where the people are.
- Some counselors should be low income people.
- Some counselors should be priests, ministers, family budgeting specialists.
- People need to be helped to fill out job applications, taken to job, and followed up.

Personal interviews held with those other than the advisory council were:

- a. Local members of the University Board of Trustees
- b. Several members of the Chancellor's staff
- c. Committee developing Educational-Occupational Preference Survey Instrument
- d. Androscoggin Regional Valley Planning Commission staff and members
- e. Agricultural Extension staff
- f. Many State Department officials
- g. Model Cities Director – Lowell, Mass.
- h. University of Maine, Orono and Farmington professors
- i. Boy Scout Director for Lewiston-Auburn area

## **2. Statement by Concerned Persons**

- a. In a brainstorming session of concerned persons in the Lewiston-Auburn area, the thinking of the community regarding the proposed two-year college crystalized into statements such as the following:

The Lewiston-Auburn area has a rich reservoir of potential of Community college students.

Having a higher percentage of educated residents will make the area more attractive to new industries since the quality of available employees will improve.

New industry attracted to the area will raise the economic level of Lewiston-Auburn and vicinity. This in turn will certainly be reflected advantageously in the economy of the state.

Industry, however, is now demanding skills and training on a level which is not now available locally. There is a need by students and industry for a broader curriculum base in the area than vocational-technical and CED.

While the above statements are predominantly practical in nature, one thought presented reflected the cultural advantages to be anticipated.

The community college will create an educational atmosphere which is generally absent in the Lewiston-Auburn area. It could lead our citizens to further interest in higher education.

- b. Training and employment problems concerning today's veterans have reached national proportions. Responsible persons in Maine are working diligently to assist the state's veterans as they reenter the tightening job market. Mr. F. W. DeRocher, Veterans counselor, Department of Veterans Services, Lewiston, was requested to comment upon the proposed community college as related to veterans' needs. He supplied the following information:

A community college can and would help returning servicemen, since the majority want to continue their education. Today many veterans are finding it extremely difficult to return to school due to a lack of availability of facilities and increasingly high cost of maintaining a family while attending school. Although the VA provides financial assistance, the amount is not sufficient for a family, especially in view of the cost of tuition, books, and related school expenses. Because of these and other constraints, many veterans are unable to upgrade and continue their education and thereby become more proficient and productive citizens in the community. While the community college will not remove all these constraints, it will resolve many of them.

There have been during the first six months of 1972, some 320 inquiries from Lewiston-Auburn area veterans regarding educational benefits. This figure is expected to double for the calendar year. It is estimated that 600 veterans are returning annually to the area.

In addition to the number of veterans qualified for educational benefits, an estimated 1,000 men and women in the area have expressed a desire to further their education. Many of these individuals would welcome an opportunity to attend, on a part-time basis, classes at the proposed community college.

- c. The Continuing Education Division (CED) Lewiston Office of the University of Maine is providing an outstanding service to the people of Lewiston-Auburn. There are approximately 1,000 area students enrolled in local CED classes. Students take from 3 to 6

credit hours per week. Many of these students are working toward a degree and commute to Portland and to Augusta for additional courses. The following statements reflect the attitude of David W. Wheller, CED Center Director, Lewiston-Auburn Branch.

The establishment of a community college would undoubtedly affect the enrollment in CED courses. In fact, an estimated 250 CED students would be diverted to the new college. However, other than this diversion it is felt that there would be no deleterious effect on CED derived from the proposed community college. In fact, the effect could be somewhat beneficial since CED would have access to a reservoir of Lewiston-Auburn Community College instructors and other personnel upon which to draw.

CED is doing a commendable job in the area, but it cannot do the complete job that a properly equipped and staffed community college could offer. A complete two year higher education offering is very necessary to the Lewiston-Auburn area and the Androscoggin Region.

### **3. Local Newspaper Articles**

Three local newspaper articles appeared in 1970 in the Lewiston Daily Sun which dealt with the possibility of a community college in Lewiston-Auburn. The first appeared on May 28, in the form of a speech given to the members of the Androscoggin Valley Regional Planning Commission (AVRPC) by Dr. Donald R. McNeil, Chancellor of the University of Maine. He indicated some disappointment in the lack of response to date from the three areas which the University's Board of Trustees had designated as locations for new community colleges: Lewiston area, York County area, and mid-coast region. McNeil's views were described in the following newspaper article:

He and Mr. Kenney (Director Central Maine Vocational Technical Institute) have discussed at length the vocational-academic education relationship and he (Chancellor McNeil) was willing to construct an academic education building on CMVTI site to provide the academic education needed in some vocational areas, but with separate jurisdictions remaining in effect. . . . Mr. McNeil referred to such an arrangement as a "unique operation" that could be broadened into the two-year community college proposed for the Lewiston area . . . There has to be some kind of two-year operation in this section of the state . . . There has to be some opportunity in the Androscoggin area.

"New Academic Service May Defeat Old" was the title of the second article dealing with the proposed community college. It was dated June 5, 1970. Members of the Androscoggin Valley Regional Planning Commission met with Bliss College representatives to discuss the community college concept and the following issue:

Overall questions and remarks . . . centered on the feasibility or impossibility of education co-existence between the proposed community college and Bliss, a private institution.

On July 3, 1970, the third significant Lewiston Daily Sun article appeared in the form of an editorial entitled "Community College." The editorial seemed to represent the local viewpoint, and the following quote from the editorial illustrated certain hopes of the community:

A two-year community college in Lewiston-Auburn would be a valuable addition to the post-high school educational opportunities now available to our people, young and old. Such an institution, as an arm of the University of Maine, would serve the second largest population area in Maine.

State Representative Louis Jalbert of Lewiston, "father" of the Central Maine Vocational-Technical Institute in Auburn and long a strong advocate of vocational training, has undertaken a campaign to bring a community college to this area. He envisions a humble beginning on the present campus of CMVTI, utilizing classrooms when they are not in use. Later, separate facilities could be provided in the same area. The two-year college would be under separate supervision but would work in cooperation with CMVTI.

On June 13, 1972, an article appeared which was a report on a speech by Rep. Louis Jalbert, made to the graduates of CMVTI. He spoke in favor of expanding the offerings of all vocational-technical institutes. He further stated:

I believe the management of these institutes is properly placed in the Department. The work of the institutes is an upward extension of vocational and occupational courses and programs in the high schools and needs to be closely tied to those programs rather than collegiate institutions . . . I do not want to see the VTIs swallowed up in another system and lose their effectiveness.

#### **4. Tech Memo 02-046-10, June 1, 1970**

In the Spring of 1970, Stuart A. Cunningham, Chief Planner for Androscoggin Valley Regional Planning Commission, conducted a quick survey of the need for a community college for the Lewiston-Auburn area.

Discussions were conducted in person, by telephone, and mail, with numerous sources including high school principals, counselors, and officials from existing local institutions.

Certain needs were cited, such as:

- (1) A community college located in the Lewiston-Auburn area, the second most populous district in Maine, will meet the diverse needs of such a growing population.
- (2) Industry is now demanding skills and training on a post-high school level not available locally at the present time. The lack of available training is a hindrance in the attraction of potential industries to the area.
- (3) The community college is a means of further education of local young people who otherwise would be denied such an education.
- (4) Students show a marked reluctance in attending Continuing Education Division classes involving more degree-oriented programs.

Some reservations were cited, such as:

- (1) There could be a duplication of facilities, with divisions of the University of Maine available in Portland and in Augusta.
- (2) The Continuing Education Division of the University of Maine and Central Maine Vocational Technical Institute are offering all the courses needed locally.
- (3) The twin cities are a nonmanufacturing community and could not afford the luxury of a community college.

The Commission sent out questionnaires to school systems in the region. The results indicated that only about 50 percent of the region's high school graduates elect to go to college, and that a decided majority of those seeking higher education leave the area.

It is believed that the establishment of a community college would result in a diversion of students from other colleges to a local community college. This diversion would be considered greatest in the core area adjacent to the college and diminish according to the distance. Therefore, as a first approximation, it was felt that a full half of the local graduating class seeking higher education would be attracted to a local school.

Calculations from the above diversion added to the anticipated diversion from CED enrollments would indicate a student body of approximately 975 after two or three years of operations.

Considerations of this diversion were based on many factors including quality instruction in programs that meet needs and interests of students, as well as the continuing economic factor that requires more and more students to live at home in the process of obtaining higher education.

## **F. Facilities Report**

Efforts have been made to determine what new concepts of facilities for community colleges are needed to implement the various programs of studies. The Freeman report revealed that present facilities of institutions of higher education in Moine are not adequate to meet the needs of expanding enrollment. The report further recommended that based on population, new facilities should be considered for less-than-baccalaureate programs in the Lewiston-Auburn industrial complex area. Literature is readily available on the subject of facility needs and planning for community colleges. In examining the experience of several other states in New England, the trend appears to be that new two-year public institutions make use of renovated space or public school buildings in order to get the doors open for students at the earliest possible date. Although there are disadvantages in using such temporary facilities, there seems to be no overwhelming education losses. On the other hand, each new institution has continued to make progress in the direction of establishing its own campus. The consensus of opinion is that the urgency of providing educational opportunity cannot wait for a capital construction program. Based on cost figures in the State of Moine, total development costs for a new community college with an enrollment of 400 FTE students would be approximately \$2 million.

Because of the immediate need to provide higher education to students and adults, as well as the costly capital outlay needed for new facilities, a survey of existing institutions in the Lewiston-Auburn area is presented with the idea of possible utilization of present facilities.

First, local institutions such as Hanson's Barber School, Mr. Bernord's School of Hair Fashion, Inc., and the Auburn Moine School of Commerce were examined in order to ascertain whether existing facilities were adequate for present enrollment. Each school seemed to be able to meet the needs of its specialized clientele with sufficient equipment and space. The Auburn Moine School of Commerce is unique among business schools of Moine in that it has the only complete campus facility. Because of the nature of these schools, together with the fact that they are privately owned and operated as businesses, it is not felt that they should be considered useful for community college service.

Second, an investigation of Botes College, a private co-educational four-year liberal arts college, was made. In discussion with the administration of this institution, no interest was expressed in possible participation in the community college level of higher education. The administration did not feel that the two-year program as proposed would fit into the mission of Botes College, which enrolls approximately ninety percent of its student body from out of state, with only two percent of the students coming from the local area.

Third, attention was given to Bliss College, a private co-educational junior college which has been in dire financial straits. The present enrollment is estimated to be about 100 students or less. While the future of this college in its present role is unclear, there is the possibility that existing facilities might be employed in a limited way in the developing stages of a community college. Bliss utilizes three converted houses, one of which serves as a dormitory, one as a combination administration, classroom, faculty offices, and library, and the third contains classrooms and laboratories.

Another local institution surveyed was Central Maine Vocational Technical Institute (CMVTI). This school is state owned and operated. The school is strategically located about three miles from the center of Auburn on a 150 acre campus. The student body has grown from forty-eight students in 1964 to about 290 full-time day students. Present plans call for a school of about 750 men and women by 1975. An Advisory Council member has stated that adequate acreage adjacent to the present CMVTI site could probably be made available for construction of a community college. This school is progressive and continues to increase its enrollment as it expands its curriculum annually. More efficient use of existing facilities could be made by extending daytime classes into the evening hours, a return to Saturday classes, and short courses and seminars during vacation periods.

From observation there seems to be other space available in the area that could be used for educational purposes such as the old Lewiston High School building, now vacant, as well as unoccupied factories and stores in the Lewiston-Auburn area which could be renovated for use. Possibilities should be explored in using the new Lewiston High School after hours. Generally, high schools and junior high schools are available in off-peak times which make for more efficient use of community resources. Usually these facilities are readily available in any community and are adaptable to most college programs including those of a vocational nature. The after school hours do allow many individuals to work on college programs on a part-time basis while being employed during the day. The Freeman report mentions that there are few major drawbacks in the use of local school facilities. Generally, the complaints heard are in the custodial area. These objections can be overcome by close supervision and the use of additional custodial help after class time to put rooms back in order.

For college-oriented programs that do not require specialized equipment, use can be made of church buildings. This type of facility is generally available and is sufficient if the classes are of a lecture or demonstration nature and do not require laboratories and special equipment.

The Freeman report reveals both advantages and disadvantages in the renovation and use of old vacated buildings. Perhaps the greatest advantage is that a college program can be started without waiting months or years before buildings can be constructed from the ground up. The report cautions that the renovation of old buildings is not always inexpensive. In addition, maintenance costs must be considered over the long run. The use of precast concrete sections, steel, aluminum, and vinyl plastic by today's construction industry indicate that the conventional building materials and methods may be "things of the past." Conventional construction costs keep spiraling, and, therefore, careful consideration to alternative techniques and materials must be given. For example, the "air-bubble" building concept may be used for such facilities as physical education or other large space use programs. This modern facility has been tried in a Maine climate such as Southern Maine Vocational-Technical Institute, and no problems are known to exist. If conversion of older buildings is to be considered at any location in Maine, the planning should include the concept that a full program of courses be offered as in a community college. This should be done to make the overall cost of conversion more economically feasible when spread over more units or instruction.

With new ideas in construction prevalent today, it is conceivable that new construction might be more economically feasible than renovation of some existing facility. Some of the new concepts in construction include use of mobile trailer units placed in such a manner as to allow stacking, connecting with each other so that each unit is a classroom or laboratory. A large amount of space can be had with a reasonable outlay of money, as well as an added feature of low maintenance due to the type of material used in construction. The use of module construction with precast concrete sections is becoming more widespread in school construction. Other types being used are steel structures put up in sections in a reasonably short time and at a rather minimal cost per square foot of usable space. Consideration can be given to the "open-space" concept of construction with the use of folding walls which make the space adaptable to either small or large class use. (Freeman)



Assuming construction for a community college would begin in 1974, what would be the estimated cost? According to the First Operational Report from the Higher Education Planning Commission, construction costs in Maine would be about \$45.59 per square foot or \$2,000,000 for 46,000 square feet of floor space which would accommodate a 400 FTE. These figures include a reasonable land cost, parking for a minimum number of cars, and economical, but permanent, type construction.

Construction costs vary from state to state, and city to city. Thus, it is only practical to consider local estimates. The Lewiston-Auburn construction costs were developed by Architect Dean Woodward for 1974 using the new Lewiston Comprehensive High School and CMVTI facilities. These facilities are of a traditional type construction.

The following are the construction cost estimates excluding land: (total budget includes surveys, borings, architect fees, engineer fees, furniture and equipment).

#### Lewiston High School

Building Construction	\$5,670,000	\$20.69 sq. ft.
Total Budget (excluding land)	\$7,760,000	\$28.32 sq. ft.
274,000 sq. ft.		
2,000 students FTE		

#### CMVTI

Building Construction	\$2,240,000	\$18.66 sq. ft.
Total Budget (excluding land)	\$3,500,000	\$29.16 sq. ft.
120,000 sq. ft.		
400 students FTE		

## **VI. ALTERNATIVES FOR ACTION**

Numerous alternatives for action have surfaced as a result of this study. These are presented below without regard to the political implications.

Basically, the study revealed that a comprehensive community college, in the fullest sense of the term, should be established immediately in the Lewiston-Auburn area as recommended in previous state studies concerning post-secondary education needs in Maine.

### **A. General**

1. Because of the present stalemate regarding the appropriate implementation of a community college statewide system in Maine, further consideration needs to be accorded the establishment of a community college state-level, planning component.

2. Upon the accomplishment of #1, the necessary extended research and planning on the community college concept can be extended.

3. A model, or models, should be developed to educate the public on the need for comprehensive community colleges in Maine.

4. Action should be taken to acquire considerable federal funding for establishing comprehensive community colleges through the recently passed Higher Education Amendments 1972. In order to qualify, states are required to "establish or designate a state commission which is broadly and equitably representative of the general public, and public and private nonprofit and proprietary institutions of postsecondary education. . . ." Among other things these state commissions would be required to "set forth a comprehensive statewide plan for the establishment, or expansion and improvements of comprehensive community colleges, or both, which would achieve the goal of making available, to all residents of the state, an opportunity to attend a community college. . . ." The state commission is also required to establish an "advisory council on community colleges . . . composed of i) a substantial number of persons in the state . . . having responsibility for the operation of community colleges; ii) representatives of State agencies having responsibility for an interest in postsecondary education; and, iii) the general public."

5. A name change should be considered -- CMVTI to Central Maine Community College.

### **B. Organizational**

1. The Lewiston-Auburn comprehensive community college should include the institution now operating as the Central Maine Vocational Technical Institute. There is a potential danger of duplication and excessive

cost when states organize both community colleges and vocational-technical schools, both of which may be attempting similar programs. It is urgent for the State of Maine to consider the role of these two types of institutions and determine how both may be developed into the most appropriate medium for rendering the multiplicity of programs needed in the (average) community.

2. A special task force could be appointed to study ways by which CMVTI might be linked to the comprehensive community college and maintain its identity and continue its specific role of educational service.

3. The comprehensive community college concept could more readily be developed in the state if a separate commission were created to administer these institutions. The vocational-technical institutes seem to be resisting the notion of becoming a part of the University of Maine System. Perhaps union with the community colleges would be more acceptable.

4. Immediately secure the services of a director or president of the proposed comprehensive community college and charge him with the responsibility of developing programs, hiring staff, arranging for temporary quarters, and other concerns.

5. The president should be permitted to develop the necessary staff required to accomplish the tasks preliminary to opening.

6. The chief administrator and his assistants should be carefully selected and include only those persons who are in complete agreement with the unique scope and purpose of the comprehensive community college.

7. The teaching staff should be carefully selected and include only those who have demonstrated excellence in the classroom and who are definitely student oriented.

8. The organization of the community college should free the institution from the control of the state university system or the State Department of Education.

9. The community college should enjoy a maximum amount of local administrative control and a minimum amount of state control.

10. The institution should be appropriately structured so that effective relationships could be maintained with secondary schools, other institutions of higher education, local businesses and industries, and the citizenry at large.

11. The comprehensive community college should not duplicate the offerings in the state's universities (except university-parallel two year programs), and the universities should not develop programs most suitable to community colleges.

## **B. Programmatic**

1. The institution, once established, should offer a full range of credit and non-credit work directly related to the Lewiston-Auburn area needs.

2. The primary purpose of the programs should be to upgrade the skill, the intellectual, the cultural, and the economic level of the area's citizenry.

3. Programs should be developed through a continued study of area manpower needs and citizen interests.

4. The offerings should include, but not be limited to, various types of short courses, institutes, workshops, conferences, clinics, forums, concerts, exhibits, studies basic college work, vocational-technical courses, and continuing education.

5. The institution should provide an extensive and effective counseling program.

6. Counseling services should reach out into the community and actually recruit students from areas such as the Model Cities section of Lewiston, from which only 10 percent of the students presently go on to any postsecondary institution.

7. The institution should practice an open door admissions policy.

8. The tuition should be kept low deliberately. No student in the area should be denied attendance because of tuition costs.

9. The Lewiston-Auburn area should be encouraged to raise revenue to provide funds which may in turn reduce or eliminate tuition.

10. Transportation should be provided free on busses serving strategic routes in the area, especially the Model Cities section.

## **C. Facilities**

1. The Lewiston-Auburn comprehensive community college should be established at the earliest possible moment. Temporary facilities which are available should be utilized to prevent delay. The federal share of expenses for the leasing of temporary facilities the first year could be as high as 70%.

2. Physical facilities planning should be initiated immediately. Prime consideration in facilities planning should be given to the programs to be offered and to the location. A possible site would be the land adjoining CMVTI which is available.

3. Facility needs can be lessened by maximum use of a cable TV channel and TV production facilities which are available at no charge in the Lewiston-Auburn area.

# BIBLIOGRAPHY

## Books

- Cheek, James E. *Minority Access to College*. New York: Schocken Books, 1971.
- Cosand, Joseph P. "The Community College in 1980." *Compus 1980*. Edited by Alvin C. Eurich. New York: Delocorte Press, 1969.
- Cross, K. Patricia. "The Role of the Junior College in Providing Postsecondary Education for All." *Trends in Postsecondary Education*. Washington, D.C.: Government Printing Office, 1970.
- Eulau, Heinz, and Quinley, Harold. *A General Report prepared for the Carnegie Commission on Higher Education. State Officials and Higher Education*. New York: McGraw-Hill Book Company, 1970.
- Furniss W. Todd. "Educational Programs for Everybody." *Higher Education for Everybody?* Washington, D.C.: American Council on Education, 1971.
- Glenny, Lyman A., and Weathersby, George B. ed. *Statewide Planning for Postsecondary Education: Issues and Design*. Boulder, Colorado: ESSO Foundation National Center for Higher Education Management Systems at Western Interstate Commission for Higher Education, 1971.
- Harlacher, Erwin L. *Effective Junior College Programs of Community Services: Rationale, Guidelines, Practices*. Los Angeles, Calif.: The Regents of the University of California, 1967.
- Hitch, Charles J. "California's Master Plan: Some Kind of Education for Nearly Everybody." *Higher Education for Everybody?* Edited by W. Todd Furniss. Washington D.C.: American Council on Education, 1971.
- Hurlburt, Allen S. *State Master Plans for Community Colleges*, Washington, D.C.: American Association of Junior Colleges, 1969.
- Masters, Nicholas A. "Some Political Problems Involved in Educational Planning." *Designing Education for the Future*, No. 3: Planning and Effecting Needed Changes in Education. Edited by Edgar L. Morphet and Charles O. Ryan. New York: Citation Press, 1967.
- Medsker, Leland L. "Community Colleges and other Education Programs Beyond the Twelfth Grade." *Designing Education for the Future*, No. 2: Implications for Education of Prospective Change in Society. New York: Citation Press, 1967.
- Morphet, Edgar L., and Ryan, Charles O., eds. *Designing Education for the Future*. New York: Citation Press, 1967.
- Pfeiffer, John. *New Look at Education*. New York: Odyssey Press, 1968
- Richardson, Richard C. Jr. *The Interim Campus*. Washington, D.C.: American Association of Junior Colleges, 1968.
- Toffer, Alvin. *Future Shock*. New York: Bantam Books, Inc. 1971.
- Vaughn, George B. *Some Philosophical and Practical Concepts for Broadening the Base of Higher Education in Virginia*. Los Angeles, Calif.: ERIC Clearinghouse for Junior Colleges, 1971.

## PUBLISHED REPORTS

- A Guide for Planning Community Junior College Facilities*. Prepared by D. Grant Morrison for U.S. Dept. of Health, Education and Welfare. Washington, D.C.: U.S. Government Printing Office, 1969.
- Carnegie Commission on Higher Education. *Less Time, More Options*. Clark Kerr, chairman. New York: McGraw-Hill Book Co., 1971.
- Carnegie Commission on Higher Education. *New Students and New Places*. New York: McGraw-Hill Book Co., 1971.
- Carnegie Commission on Higher Education. *State Officials and Higher Education*. Prepared by Heinz Eulau and Harold Quinley. New York: McGraw-Hill Book Co., 1970.

- Cornegie Commission on Higher Education. *The Open-Door Colleges*. New York: McGraw-Hill Book Co., 1970.
- Center for Research and Development in Higher Education. University of California, Berkeley, Vol. IV.
- Higher Education in the State of Maine. James S. Coles, chairman. Report of the Advisory Commission for the Higher Education Study to the Governor of Maine and the Legislature of the State of Maine: Maine: n.p., 1967.
- Higher Education Planning for Maine. Frank M. Coffin, chairman, First Operational Report from the Higher Education Planning Commission: Maine, 1972.
- Maine Pocket Data Book 1971, An Economic Analysis. Department of Economic Development. Galen Rose, Project Manager. Maine Department of Economic Development, 1971.
- Maine's Public Investment Needs of Highest Priority. A report submitted by ESCO Research, Inc., to the Governor of Maine, Portland, Maine: ESCO Research, Inc., 1970.
- Meeting Maine's Basic Responsibilities for Higher Education. A special report to the Maine State Board of Education. James C. McCain, chairman. New York Academy for Educational Development, Inc., 1966.
- National Education Finance Project Special Study No. 6. *The Community Junior College Target Population, Program Costs and Cost Differentials*. Gainesville, Florida: Institute of Higher Education, University of Florida, 1970.
- Report of the President's Task Force on Higher Education. *Priorities in Higher Education*. Washington, D.C.: Government Printing Office, 1970.
- Report of the State of Maine Higher Education Facilities Commission. *Higher Education in Maine: Its Facilities and Utilization*. Charles F. Bragg II, chairman. New York: Institute for Educational Development, 52 Vanderbilt Ave., 1970.
- Report on Higher Education. Frank Newman, chairman. Washington, D.C.: Government Printing Office, 1971.
- Report Submitted by ESCO Research, Inc. to the Governor of Maine. "Education." *Maine's Public Investment Needs of Highest Priority*. Portland, Maine: ESCO Research, Inc., 1970.
- Sutton, Ronnie N. *Community College or Four Year Program*. Bulletin of the Bureau of School Service, Vol. XLIII., Lexington, Kentucky, College of Education. University of Kentucky, 1970.
- The First Business of Our Times*. A report of the Advisory Commission for the Higher Education Study, State Maine. James A. McCain, chairman, New York: Academy for Educational Development, 1971.
- Trends in Postsecondary Education*. U.S. Department of Health, Education and Welfare, Washington, D.C. U.S. Government Printing Office, 1970
- Trent, James W. "The Decision to Go to College: An Accumulative Multivariate Process" *Trends in Post-Secondary Education*. Washington, D.C.: Government Printing Office, 1970.

#### UNPUBLISHED REPORTS

- Freeman, Jr., Dr Stanley L A Report to the State of Maine Higher Education Facilities Commission *Special Opportunity Facilities Planning Project*. University of Maine, 1971. (Mimeographed)
- Morley, Harvey. "Systems Approach to Master Planning for Education Facilities" University of Alabama, 1972
- Progress Report of the Higher Education Planning Commission to the Chancellor of the University of Maine. Frank M Coffin, chairman University of Maine, 1969
- Report of the Advisory Commission for the Higher Education Study to the Governor of Maine and the Legislature of the State of Maine *Higher Education in the State of Maine*. James S. Coles, chairman. Maine, 1967.
- Report of the Board of Trustees of the University of Maine. Lawrence M. Cutler, chairman. University of Maine, 1969
- Report of the Chancellor's Task Force on Less Than-Baccalaureate Degree Programs. Edward Y. Blewett, chairman University of Maine. May 11, 1970. Mimeographed)

# APPENDIX A

APPENDIX A

IMPLEMENTATION PROCESS FOR THE LEWISTON-AUBURN AREA

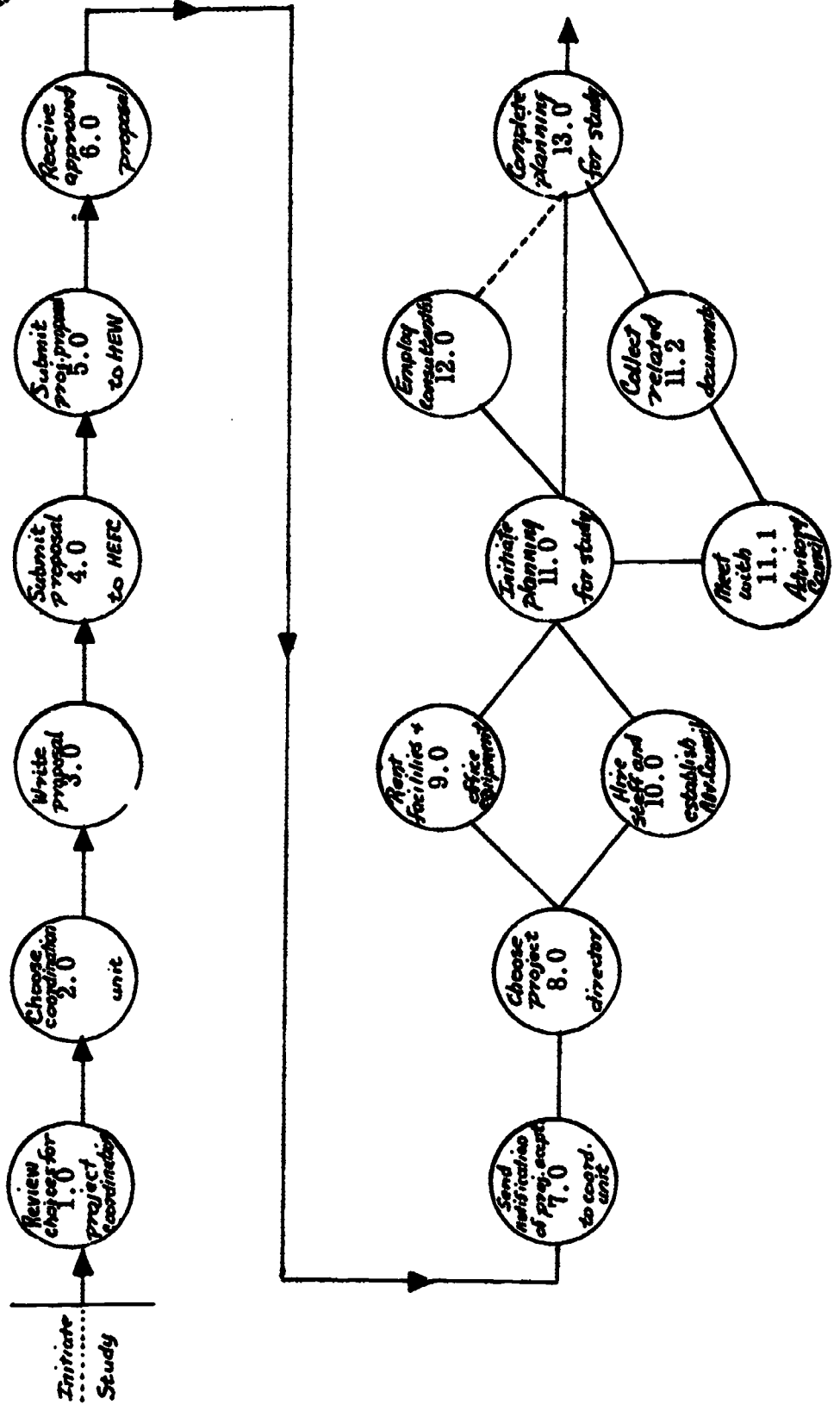



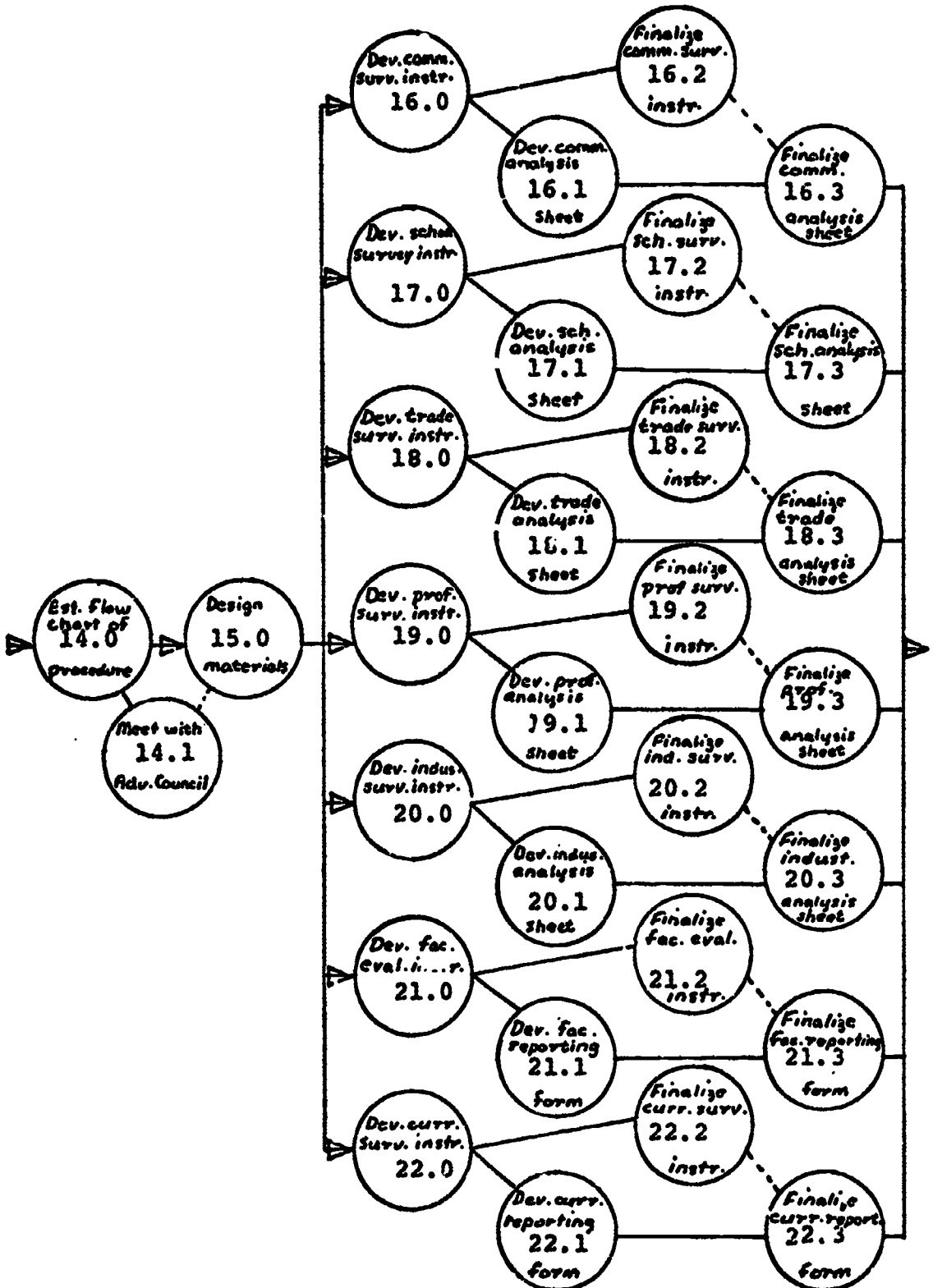

BEST COPY AVAILABLE

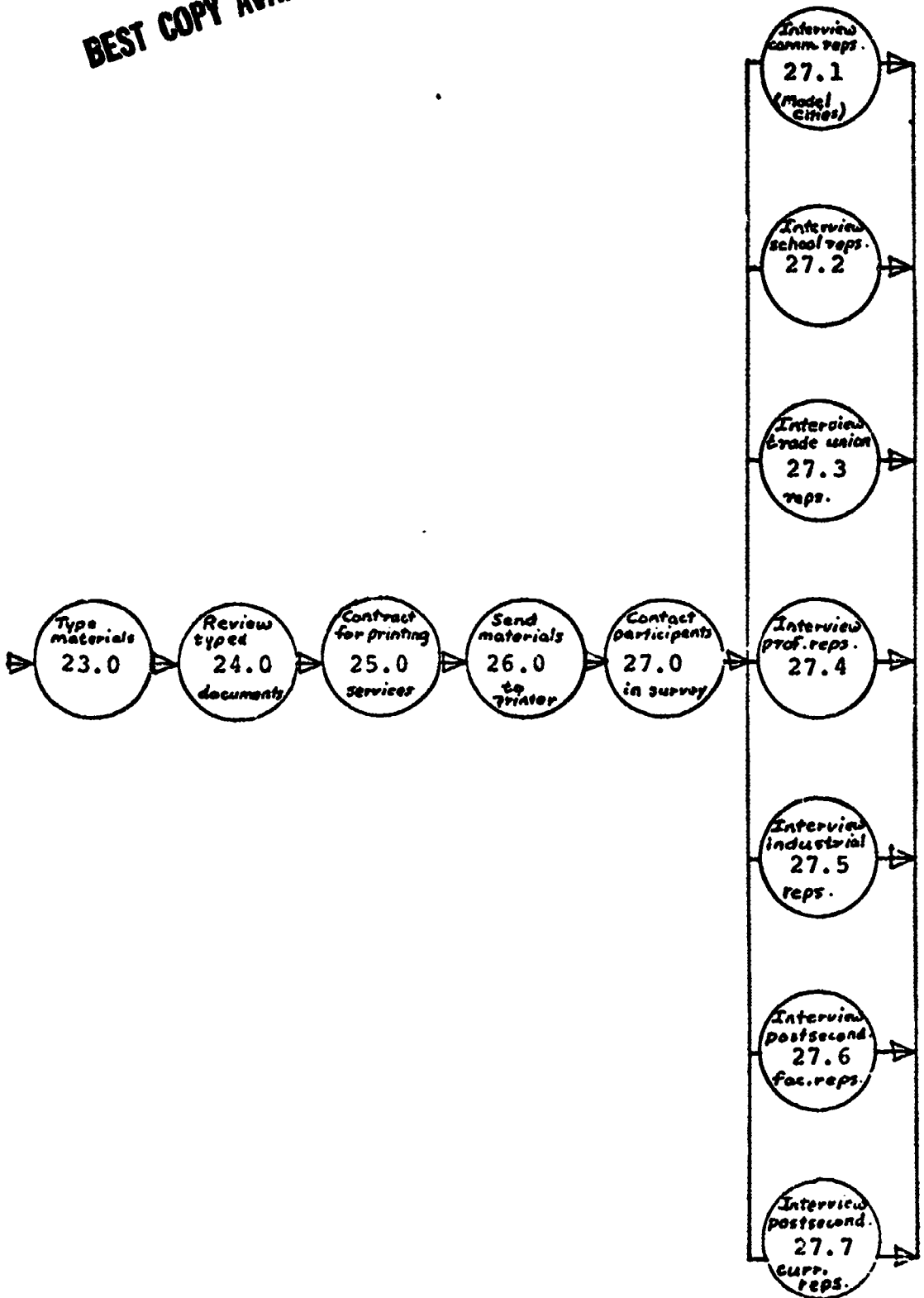

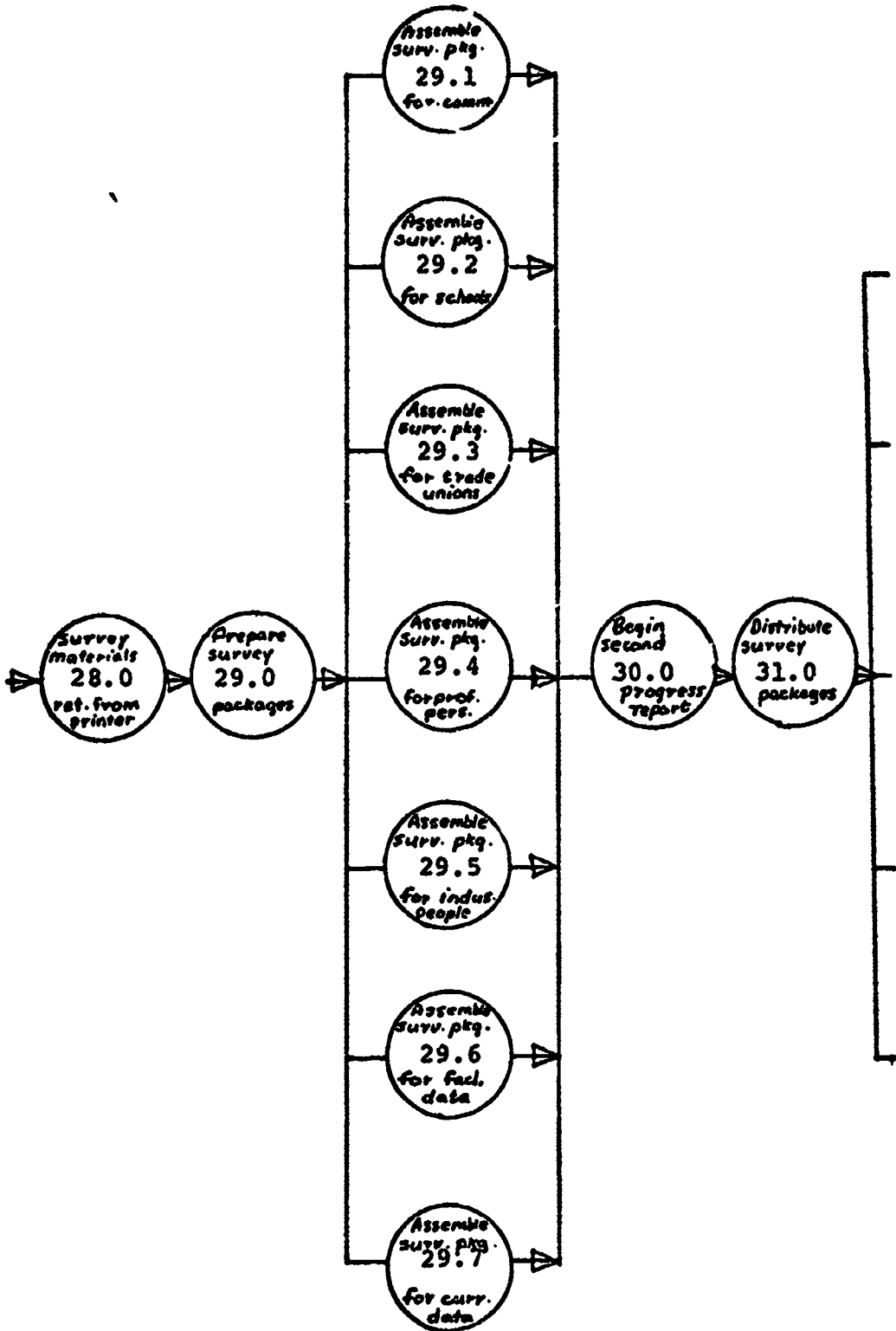

BEST COPY AVAILABLE

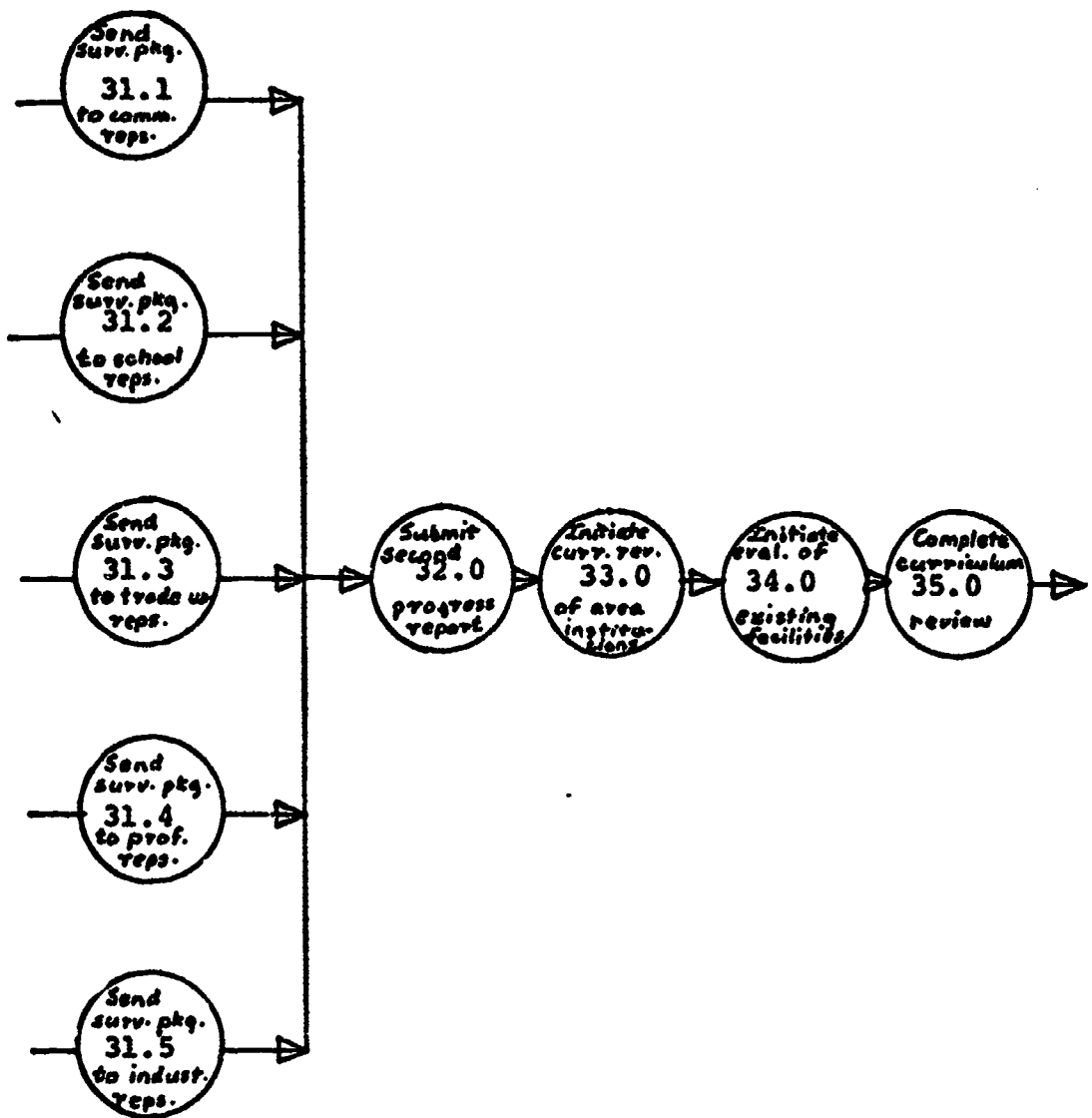

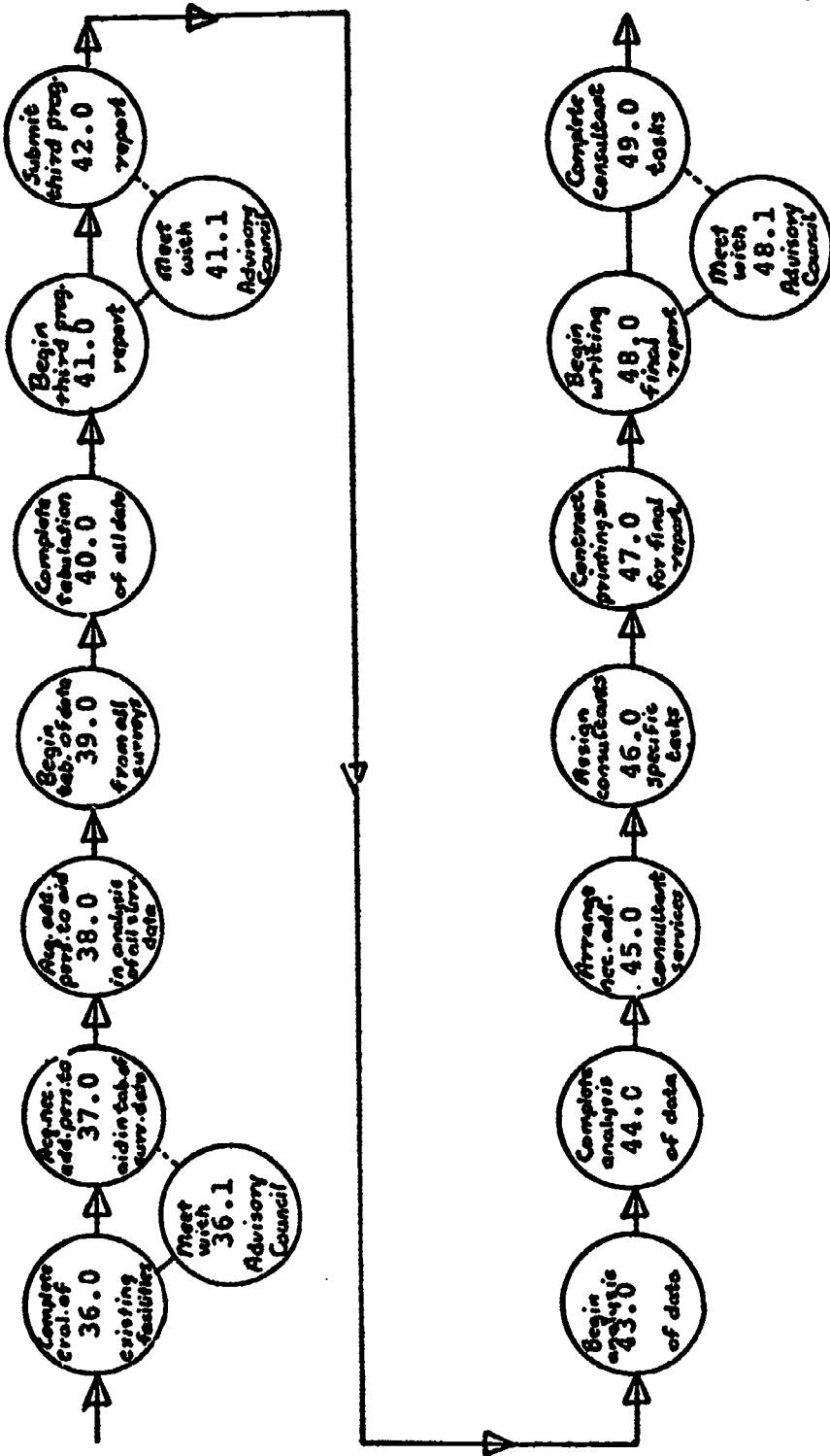

BEST COPY AVAILABLE

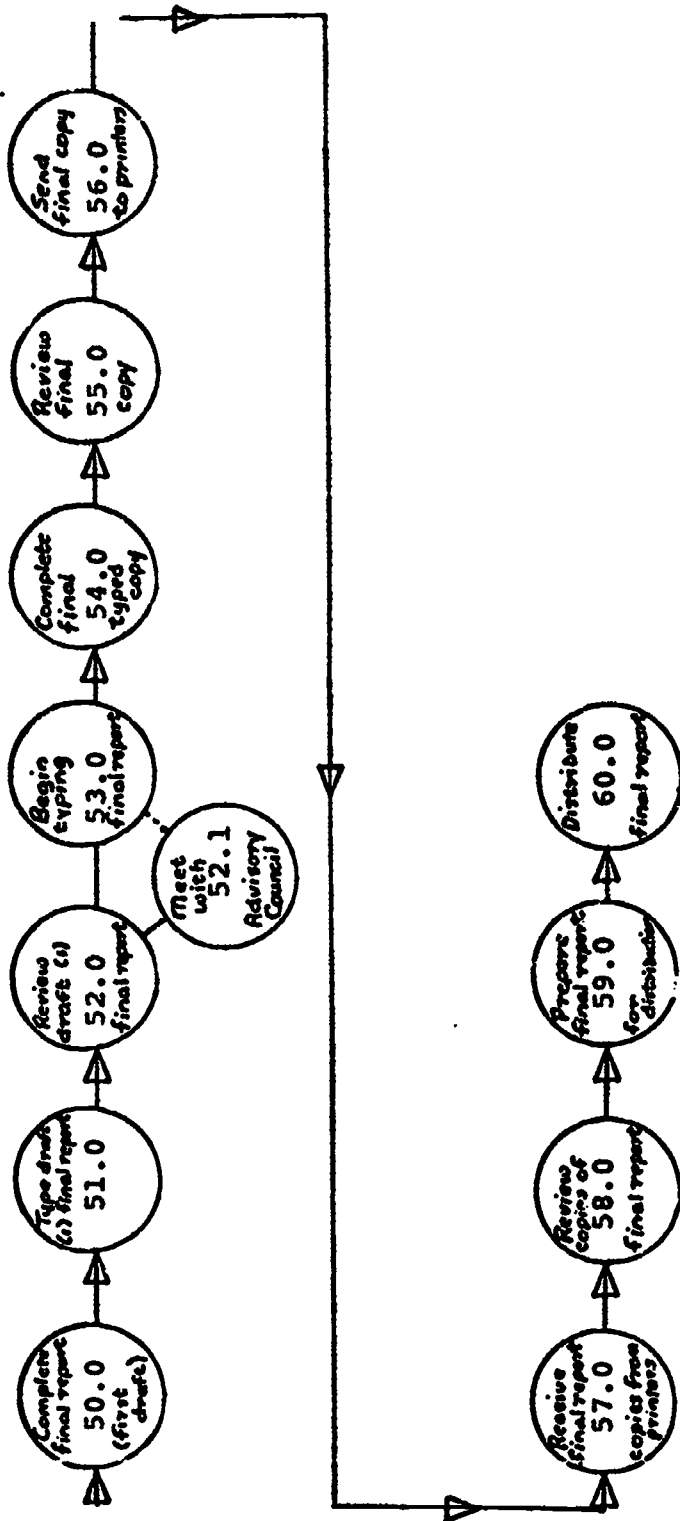

**The following is a consolidated narrative for implementation process**

- 1.0 Review choices for project coordination**
- 2.0 Choose coordination unit**
- 3.0 Write proposal**
- 4.0 Submit proposal to Higher Education Facilities Commission (HEFC)**
- 5.0 Submit project proposal to Health, Education and Welfare**
- 6.0 Receive approved proposal**
- 7.0 Send notification of project acceptance to coordination unit**
- 8.0 Choose project director**
- 9.0 Rent facilities and office equipment**
- 10.0 Hire staff and establish Advisory Council**
- 11.0 Initiate planning for feasibility study**
  - 11.1 Meet with Advisory Council**
  - 11.2 Collect related documents**
- 12.0 Employ consultant(s)**
- 13.0 Complete planning for feasibility study**
- 14.0 Establish flow chart of procedures**
  - 14.1 Meet with Advisory Council**
- 15.0 Design materials**
- 16.0 Develop community survey instrument**
  - 16.1 Develop community analysis sheet**
  - 16.2 Finalize community survey instrument**
  - 16.3 Finalize community analysis sheet**
- 17.0 Develop school survey instrument**
  - 17.1 Develop school analysis sheet**
  - 17.2 Finalize school survey instrument**
  - 17.3 Finalize school analysis sheet**
- 18.0 Develop trade survey instrument**
  - 18.1 Develop trade analysis sheet**
  - 18.2 Finalize trade survey instrument**
  - 18.3 Finalize trade analysis sheet**
- 19.0 Develop professional survey instrument**
  - 19.1 Develop professional analysis sheet**
  - 19.2 Finalize professional survey instrument**
  - 19.3 Finalize professional analysis sheet**
- 20.0 Develop industrial survey instrument**
  - 20.1 Finalize industrial analysis sheet**
  - 20.2 Finalize industrial survey instrument**
  - 20.3 Finalize industrial analysis sheet**
- 21.0 Develop facilities evaluation instrument**
  - 21.1 Develop facilities reporting form**
  - 21.2 Finalize facilities evaluation instrument**

- 21.3 Finalize facilities reporting form
- 22.0 Develop curriculum survey instrument
- 22.1 Develop curriculum reporting form
- 22.2 Finalize curriculum survey instrument
- 22.3 Finalize curriculum reporting form
- 23.0 Type materials
- 24.0 Review typed documents
- 25.0 Contract for printing services
- 26.0 Send materials to printer
- 27.0 Contact participants in survey
- 27.1 Interview community representatives (Model Cities)
- 27.2 Interview school representatives
- 27.3 Interview trade union representatives
- 27.4 Interview professional representatives
- 27.5 Interview industrial representatives
- 27.6 Interview postsecondary facilities representatives
- 27.7 Interview postsecondary curriculum representatives
- 28.0 Survey materials returned from printer
- 29.0 Prepare survey packages
- 29.1 Assemble survey package for community
- 29.2 Assemble survey package for schools
- 29.3 Assemble survey package for trade unions
- 29.4 Assemble survey package for professional personnel
- 29.5 Assemble survey package for industrial people
- 29.6 Assemble survey package for facilities data
- 29.7 Assemble survey package for curriculum data
- 30.0 Begin second progress report
- 31.0 Distribute survey packages
- 31.1 Send survey package to community representatives
- 31.2 Send survey package to school representatives
- 31.3 Send survey package to trade union representatives
- 31.4 Send survey packages to professional representatives
- 31.5 Send survey packages to industrial representatives
- 32.0 Submit second progress report
- 33.0 Initiate curriculum review of area institutions
- 34.0 Initiate evaluation of existing facilities
- 35.0 Complete curriculum review
- 36.0 Complete evaluation of existing facilities
- 36.1 Meet with Advisory Council
- 37.0 Acquire necessary additional personnel to aid in tabulation of survey data
- 28.0 Acquire additional personnel to aid in analysis of all survey data
- 39.0 Begin tabulation of data from all surveys



- 40.0 Complete tabulation of all data**
- 41.0 Begin third progress report**
- 41.1 Meet with Advisory Council**
- 42.0 Submit third progress report**
- 43.0 Begin analysis of data**
- 44.0 Complete analysis of data**
- 45.0 Arrange necessary additional consultant services**
- 46.0 Assign consultants specific tasks**
- 47.0 Contract printing services for final report**
- 48.0 Begin writing final report**
- 48.1 Meet with Advisory Council**
- 49.0 Complete consultant tasks**
- 50.0 Complete final report (first draft)**
- 51.0 Review draft (1) final report**
- 52.1 Meet with Advisory Council**
- 53.0 Begin typing final report**
- 54.0 Complete final typed copy**
- 55.0 Review final copy**
- 56.0 Send final report to printers**
- 57.0 Receive final report copies from printers**
- 58.0 Review copies of final report**
- 59.0 Prepare final report for distribution**
- 60.0 Distribute final report**

## **APPENDIX B**

**SURVEY OF EDUCATIONAL - OCCUPATIONAL  
PREFERENCES OF MAINE SECONDARY  
SCHOOL STUDENTS**

**HIGH SCHOOLS SURVEYED:**

Lewiston High School  
Edward Little High School  
St. Dominic Regional High School  
Lisbon High School  
Buckfield High School  
Leavitt Area High School  
Gray-New Gloucester High School

**TOTAL STUDENTS:**

2246

**TWO SCHOOLS DID NOT  
CHOOSE TO COOPERATE:**

Lake Region High School  
Oxford Hills High School

State Department of Education  
Augusta, Maine  
and  
The University of Maine

Pilot Test - February, 1972

Developed by  
Education - Occupation  
Survey Committee

**CONFIDENTIAL**

The purpose of this survey is to gather planning and development data from the educational and career preferences of Maine high school students. Information collected in this survey will be utilized to develop new career training programs, revise existing curriculum offerings, plan new physical facilities, and provide extended guidance and counseling to students.

**PART I GENERAL INFORMATION:** To be completed by each student. All responses will be treated confidentially and the anonymity of each individual is assured.

NAME .....  
 Last First Middle  
 ADDRESS: .....  
 TOWN OR CITY .....  
 SCHOOL: ..... PUBLIC ..... PRIVATE .....  
 SEX: .... Male ..... Female AGE: .....  
 YEAR OF SCHOOL: ..... Freshman ..... Sophomore ..... Junior ..... Senior ..... Other

1. In what area have you taken most of your High School courses? Place a ✓ on the appropriate blank.

- |                             |  |
|-----------------------------|--|
| 1. College Prep or Academic | 4. Vocational, Industrial, or Practical Arts |
| 2. General                  | 5. Other                                     |
| 3. Commercial or Business   |  |

2. My father is employed in the following occupational area: Place a ✓ on the appropriate blank.)

#	#	
4.6	173	1. Agriculture, fishing, forestry occupations such as farmers, foresters, etc.
1.7	38	2. Bench work occupations such as TV repairman, electronics assembly, watch repair, etc.
12.7	284	3. Clerical-sales occupations such as secretaries, salesmen, clerks, etc.
12.1	270	4. Machine trade occupations such as machinists, printers, mechanics, cabinetmakers, etc.
11.7	258	5. Miscellaneous occupations such as truckers, warehousemen, photographers, actors, miners, etc.
12.9	288	6. Processing occupations such as workers in oil, steel, plastics, leather, wood, and other processing industries
6.8	216	7. Professional/technical occupations such as engineers, doctors, teachers, etc.
11.1	247	8. Service occupations such as policemen, beauty operator, cooks, etc.
12.7	295	9. Structural work occupations welders, painters, electricians, grinding, etc.
11.5	256	10. Unemployed, retired, disabled, deceased or don't know
		11. Write father's occupation .....

3. My mother is employed in the following occupational area.

	%	#
1. Agriculture such as nursery worker, field worker, home advisor, etc.	1.6	36
2. Bench work occupations such as garment cutter, assembler, manufacturing inspector, etc.	5.4	120
3. Clerical work occupations such as secretary, saleswomen, clerks, etc.	15.0	337
4. Housewife	42.5	946
5. Machine trade occupations such as printer, sewing machine operator, office machine operator, etc.	4.5	101
6. Miscellaneous occupations such as photographer, actress, writer, etc.	1.2	29
7. Processing occupations such as workers in food, plastic, leather, wood, and other processing industries	9.0	202
8. Professional technical occupations such as engineers, doctors, teachers, etc.	7.4	166
9. Service occupations such as policewomen, beauty operators, cooks, etc.	5.1	115
10. Unemployed, retired, disabled, deceased or don't know	8.3	185
11. Write mother's occupation		

Total = 2237

4. Language spoken MOST often at home:

1. English	1891 = English
2. French	208 = French
3. German	1 = Hungarian
4. Hungarian	1 = Polish
5. Indian	1 = Spanish

Total = 2102

5. How many years of schooling did your mother, father complete. Check the appropriate category.

Mother		Father		Father	
#	%	#	%	#	%
1. 446	20.0	1.	1 through 8 years	535	24.3
2. 348	17.7	2.	1 to 3 years of high school	377	17.1
3. 85	3.9	3.	4 year high school diploma	635	28.9
4. 242	11.2	4.	1 to 3 years beyond high school - technical school, college,	239	10.8
5. 74	3.2	5.	College degree (nursing, etc.)	91	4.1
6. 23	1.1	6.	Advanced college or professional degree training	106	4.9
7. 170	7.6	7.	Unknown	219	9.9

Total = 2234

Total = 2202

6. What is the total number of communities you have lived in IN LUTHER, your present community?

1. One community	6. Six communities	Total 1092 Communities
2. Two communities	7. Seven communities	
3. Three communities	8. Eight communities	Total 2243 respondents
4. Four communities	9. Nine communities	
5. Five communities	10. Ten or more communities	= 1.7 comm./resp.

7. How many children are in your family in, including yourself:

1. One child	6. Six children	Total 11566 children
2. Two children	7. Seven children	
3. Three children	8. Eight children	Total 2244 respondents
4. Four children	9. Nine children	
5. Five children	10. Ten or more children	= 1.7 children/family

10. What is your estimate of your academic rank in class?

19.8	1.4	1	I think I am in the upper third of my class.
12.8	1.8	2	I think I am in the middle third of my class.
11.4	2.0	3	I think I am in the lower third.

Total = 3172

**PART II INTEREST INVENTORY**

11. I am most interested in the following high school subject(s) area:

%	#		%	#		%	#
4.7	137	1	19.5	438	7	Mathematics	
19.4	442	2	7.7	173	8	Mus., Fine Arts	
16.7	375	3	18.7	417	9	Physical Education - Athletics	
6.6	124	4	14.8	330	10	Practical Arts and Vocational Education	
6.6	125	5	16.1	362	11	Science	
7.1	149	6	15.8	246	12	Social Science	

0.27 6-13 Other (Please specify) .....

Total = 3293

12. At this time, my first choice of a career for which I have the necessary ability and a good chance for success after graduation from high school or college is in:

%	#		%	#
9.0	161	1	Agriculture, fishing, forestry occupations (farmers, foresters, etc.)	
2.6	51	2	Home work occupations (TV repairmen, electronics assembly, watch repair, etc.)	
23.0	424	3	Clerical sales occupations (secretaries, salesmen, clerks, etc.)	
6.7	122	4	Machine trade occupations (machines, printers, mechanics, cabinetmakers, etc.)	
9.4	198	5	Miscellaneous occupations (truckers, w.r. housemen, photographers, actors, singers, etc.)	
1.9	40	6	Processing occupations (workers in oil, steel, plastic, leather, wood, and other processing industries)	
29.0	611	7	Professional/technical occupations (engineers, doctors, teachers, etc.)	
9.1	191	8	Service occupations (policemen, beauty operators, cooks, etc.)	
9.6	211	9	Structural work occupations (welders, painters, electricians, grinding, etc.)	

Total = 2110

**PART III EDUCATIONAL PLANS**

13. Do you intend to continue your education after high school?

9.0	# 1487	% 31.0	# 662
	1) Yes	Total=2148	2) No

If you checked "no" go directly to item No. 15. If you checked "yes" continue with next item.

14. If you do plan to continue your education, what financial arrangements have you made? (Mark all that apply):

%	#		%	#		%	#
21.3	319	1	51.6	767	4	Part time work	
46.6	693	2	16.9	251	5	Scholarship	
21.3	318	3	18.5	275	6	Self support	

0.9 24 7. Other (please specify) .....

Total = 2647

# BEST COPY AVAILABLE

13. What type of school do you wish to attend?

(1) A campus of the University of Maine	(4) A public college or university outside the state
(2) A private college in Maine	(5) A vocational-technical institute
(3) A private college outside the state	(6) Don't know at this time
(7) Other (please specify) .....	% # .....

1. 24.1	359	4. 8.9	132
2. 7.2	107	5. 23.2	345
3. 7.2	105	6. 27.8	412
			Total-1577

14. If you had a chance to attend a low cost two year community college within 20 miles of your home would you choose this in preference to your answer to No. 13 above?

(1) Yes	7.2	7.8	117	
(2) No	45.5	683		
	54.5	803	Total - 1486	

Proceed to Item No. 18 if you answered Items No. 12, 13 and 14.

15. What are the reasons for not continuing your education? (Check ----- as many as apply.)

(1) I can get along without a college education	%	#
(2) I can't afford it	14.6	97
(3) My grades aren't good enough	27.0	179
(4) Parents don't want me to	32.5	215
(5) Tired of school, had enough education	1.8	12
(6) Want to get married	34.0	228
(7) Want to join the Army, Navy or Marines	25.0	163
(8) Want to work and make money	21.6	143
(9) Other (please specify) .....	44.5	295
	3.6	24
Total - 1356		

16. If you had a chance to attend a low cost two year community college or vocational-technical institute within 20 miles of your home would this change your thinking about continuing your education?

(1) Yes	39.0	258
(2) No	61.0	394
Total - 652		

17. Would a combination of financial assistance and community college near your home change your thinking about continuing your education?

(1) Yes	41.5	284
(2) No	58.5	366
Total 650		

18. How do you think your parents feel about your continuing your education beyond high school? (Select one)

(1) Insist or expect me to continue	%	#
(2) They don't care one way or the other	23.2	512
(3) They don't want me to continue	5.8	130
(4) Want me to go if I want to	1.0	23
(5) Won't allow me to continue	69.0	1518
(6) Other .....	0.1	2
	2.0	20
Total - 2205		

**PART IV. OCCUPATIONAL AND VOCATIONAL INTERESTS**

**BEST COPY AVAILABLE**

Below is a list of several major fields of study grouped into 18 general categories. Section A includes programs that generally require two years for completion and are offered in community colleges or vocational technical institutes. Section B includes four year programs offered in private colleges and the state university.

In answering the next questions please do the following:

- A. Select the section in which you are most interested. Section A for two year programs; Section B, page 7 for four year programs.
- B. Select the category or categories within A or B that interest you most.
- C. For the categories selected indicate your level of interest in a career program by recording 1, 2 or 3 in the blank at the left of each area:
  - 1 Indicates a high degree of interest
  - 2 Indicates some interest
  - 3 Indicates little or no interest

You may omit answers in any category in which you have no interest whatsoever.

**Section A Two Year Programs (1180 filled out section A)**

**Category 1 Business Administration (723, 1.95\*) [2897]**

#	Rating	#	Rating
335	1.96	Accounting	328 1.40
245	2.02	Banking	243 1.67
260	1.97	Business Administration General	214 2.15
217	2.18	Computer Science	181 1.80
287	1.87	Data Processing	188 2.33
191	2.40	Distributive Education	266 1.52

**Category 2 Environmental Studies (571, 1.96) [762]**

#	Rating	
153	2.12	Environmental Technology
277	1.64	Forest Ranger Aide
171	2.03	Public Environmental Health Technology
161	2.10	Waste Water Treatment Technology

**Category 3 Food Services (354, 2.01) [472]**

#	Rating	
136	1.97	Culinary Arts
116	1.91	Food Processing
129	1.86	Food Service Management
91	2.30	Institutional Foods

**Category 4 Engineering and Mechanical (369, 2.06) [2575]**

#	Rating	#	Rating
118	2.34	Air Conditioning Repair	124 2.20
138	2.11	Architectural and Civil Engineering	112 2.21
221	1.82	Automotive Body Repair	118 2.20
192	1.78	Automotive Technology	106 2.40
103	2.42	Chemical Engineering Technology	119 2.29
107	2.24	Chemical Technology	121 2.20
126	2.14	Civil Engineering Technology	121 2.18
125	2.02	Electrical Engineering Technology	115 2.17
118	2.16	Electrical Power Technology	96 2.70
134	2.02	Electronics Technology	113 2.40
		Heating and Air Conditioning	
		Heating and Oil Burner	
		Industrial Electricity	
		Instrument Technology	
		Machine Drafting and Mechanical Technology	
		Machine Tool Technology	
		Mechanical Engineering Technology	
		Multimed Radio-TV	
		Process Control	
		Radio-TV Service Repair	



# BEST COPY AVAILABLE

## Category 5 Agriculture (368, 1.74) [718]

	#	Rating
- Agriculture Power Machines	132	2.00
Animal Medical Technology	155	1.70
Animal Technology	160	2.40
Forest Management	217	1.78
Resource and Business Management	114	1.89

## Category 6 - Building Trades (322, 1.98) [1076]

144 Building Construction Technology	1.70	98 Heating and Plumbing	1.80
155 Carpentry and Boat Building	2.02	120 Heavy Equipment Maintenance	1.93
75 C.E.M.A.	2.02	106 Masonry Brick Laying	1.98
107 Drafting	2.10	90 Modified Building Trades	1.98
103 Electrical Construction	2.16	78 Sheet Metal	2.16

## Category 7 Liberal Arts (375, 2.33) [375]

	#	Rating
Art	179	1.70
General Education	130	1.99
Liberal Arts Transfer	66	2.88

## Category 8 Health Services (441, 1.96) [937]

109 Allied Health and Social Services	2.31	139 Medical Lab Technician	2.10
153 Health Care Administration	1.96	166 Mental Health Worker	1.77
154 Health Medical Assistant	1.93	146 Nursing	1.73
166 Licensed Practical Nurse	1.96		

## Category 9 Social Services (402, 1.85) [847]

127 Community Service Aide	1.88	150 Law Enforcement Technology	1.86
124 Criminal Justice	1.20	93 Public Administration	2.00
135 Criminal Justice Corrections Parole	2.12	179 Recreation	1.87
125 Fire Service Technology	2.02		

## Category 10 Miscellaneous (423, 1.91) [842]

	#	Rating
Aviation	185	1.66
Cosmetology	120	1.92
Graphic Arts and Printing Technology	110	2.06
Hotel Motel Management	134	2.08
Marine Biology and Ichthyography	160	1.81
Marine Science	178	1.98

## Section B Four Year Programs (847) filled out section B)

## Category 1 Arts and Humanities (800, 2.03) [2068]

181 Architecture	1.81	162 Language other	2.28
219 English Literature	1.81	188 Music	1.95
176 Fine Arts	2.04	200 Philosophy	1.92
206 History	1.96	181 Speech and Drama	2.02
208 Journalism writing	1.96	156 Theology	2.38
176 Language modern	2.14	21 Other	2.10

Category 2 Biological Sciences (44,900,2) [467]

#	Rating		#	Rating	
109	2.00	Biochemistry	11	1.97	Botany
102	1.44	Biology general	127	1.79	Zoology
93	2.43	Biophysics	1	2.60	Other

Category 3 Business Administration (44,910,10) [444]

#	Rating	
100	1.92	Accounting
113	1.84	Business Administration
113	2.00	Electronic data processing
96	2.00	Secretarial Studies
13	2.20	Other

Category 4 Engineering (44,920,14) [488]

#	Rating		#	Rating	
106	1.94	Aeronautical	59	2.30	Industrial
80	2.22	Chemical	69	2.17	Mechanical
81	2.11	Civil	5	1.80	Other
82	2.42	Electrical			

Category 5 Physical Science (44,930,99) [768]

#	Rating		#	Rating	
144	2.04	Chemistry	165	1.90	Physics
143	2.10	Earth Science	101	2.18	Statistics
189	1.54	Mathematics	1	2.20	Other

Category 6 Professional (44,940,103) [952]

#	Rating		#	Rating	
143	1.92	Health Technology - medical, dental, laboratory			Premedical
170	1.98	Nursing	144	1.90	Preceptors
131	2.21	Pharmacy	129	2.24	Therapy
125	2.38	Podiatry	135	1.99	Other
147	2.00	Prelaw	28	1.63	

Category 7 Social Science (44,950,100) [1509]

#	Rating		#	Rating	
163	2.24	Anthropology	25	1.76	Psychology
161	2.40	Economics	243	1.87	Social Work
200	1.80	Education	185	1.95	Sociology
191	2.04	History	11	1.80	Other
165	2.04	Political Science - government, international relations			

Category 8 Other Fields (44,960,15) [1071]

#	Rating		#	Rating	
94	2.00	Agriculture	7	2.72	Industrial Arts
94	2.01	Communications - radio, TV, etc.	14	2.40	Library Science
130	2.00	Computer Science	18	2.31	Military Science
162	2.05	Environmental Science	121	1.86	Physical Education and Recreation
77	2.38	Electronics Technology	10	2.30	Other technical
133	1.64	Forestry	18	2.33	Other technical
78	2.30	Home economics	1	2.88	Other non technical
			5	2.10	Undecided

Please accept our thanks for participating in this survey of educational occupational plans of Maine high school students.

# APPENDIX C

# CONSOLIDATED COURSE MATRIX KEY

1. **Administration and Management**
  - administration and management
  - commercial business administration
  - industrial supervision and management
  - petroleum marketing
  - public administration
  - technical supervision
2. **Agriculture**
  - agriculture business
  - agriculture engineering
  - agriculture science
  - agricultural supply
  - animal husbandry
  - citrus fruits and production management
3. **Art**
  - advertising art
  - art
  - biological illustrations
  - commercial art
  - fine arts
  - graphic arts
  - design
  - drafting
  - architectural design and drafting
  - architecture
  - interior decorating
  - fashion design
4. **Business**
  - banking and insurance
  - business
  - business education
  - business machine technology
  - industrial business
  - office machines and procedures
  - clothing technology
  - public and industrial relations
  - fashion merchandising

- general merchandising
  - salesmanship and retailing
  - journalism
- 5. **Communications**
  - broadcasting
  - communications
  - radio-television
  - television production technology
- 6. **Child Development and Nursery Education**
  - child development
  - day care center administration
  - nursery education
- 7. **Hotel, Motel and Restourant Technology**
  - cafeterial management
  - commercial baking
  - food and motel technology
  - food marketing management
  - foodservice administration
- 8. **Marketing and Advertising**
  - advertising
  - marketing and management
  - marketing and retailing
- 9. **Mechanics**
  - automobile body repair
  - agricultural machinery and mechanics
  - automobile mechanics and technology
  - mechanics
- 10. **Health and Related Occupations**
  - medical assisting
  - medical laboratory assisting (medical technology on an occupational basis)
  - medical records librarian
  - medicol technology (transfer)
  - medicine (transfer)
  - ophthalmic dispensing
  - optical technology
  - optometry
  - pharmacy
  - physical education and recreation
  - podiatry

**radiology and x-ray technology**  
**nursing (practical)**  
**nursing (psychiatric)**  
**nursing (registered)**  
**laboratory technology**  
**health and safety**  
**home economics**  
**data processing dental assisting**  
**dental hygiene**  
**dental technology**  
**dentistry (transfer)**  
**prosthetics**  
**psychology**  
**social service work**  
**sociology**

**11. Religion**

**Christian education**  
**church staff worker**  
**deaconess**  
**ministry**  
**religion**  
**theology**

**12. Sciences**

**biological science**  
**chemistry**  
**earth sciences**  
**geology**  
**life sciences**  
**marine science**  
**natural science**  
**physical science**

**13. Secretarial and Clerical**

**bilingual secretarial science**  
**insurance secretarial**  
**legal secretarial**  
**medical secretarial**  
**parish secretarial**  
**secretarial and clerical**  
**court reporting**

**14. Airline Related Jobs**

**aviation**

**flight training  
pilot training  
airline hostess**

**15. Teaching**

**education  
teaching  
teaching aide  
(see Child Development and Nursery Education)**

**16. Forestry and Conservation**

**conservation  
fisheries  
forestry  
wildlife conservation and management**

**17. General Education**

**speech and drama  
metal and machine  
criminology  
design  
drafting  
fire science  
foreign language  
electricity and electronics  
police science  
photography  
mathematics**

**18. Trades – Occupational**

**apprenticeship  
dry cleaning  
millworking  
paper technology  
plumbing  
upholstering  
trades and industrial arts  
transportation and commerce  
veterinary science  
woodworking and carpentry  
building contracting  
construction  
barbering  
cosmetology  
gunsmithing**

**machinist  
printing  
industrial education  
mortuary science  
surveying**

**19. Technological Courses**

**industrial engineering technology  
(occupational)  
industrial laboratory technology  
instrumentation technology  
air-conditioning engineering technology  
(occupational)  
architectural and civil engineering  
(occupational)  
chemical engineering technology  
engineering design technology  
engineering technology (occupational)  
electrical and electronic engineering technology  
(occupational)  
fuel technology (occupational)  
materials engineering technology (occupational)  
welding technology  
metallurgical engineering technology (occupational)  
nuclear technology (occupational)  
textile engineering technology (occupational)  
quality control technology  
machine technology**



## **APPENDIX D**

**BEST COPY AVAILABLE**

ARTHUR O CLARK  
PLANNING DIRECTOR

City of Lewiston  
Maine

TEL. 207 784-4244  
ZIP CODE 04240

Planning Department

September 8, 1972

Dr. Larry Stinchcomb  
University of Maine  
Farmington, Maine 04938

Dear Larry,

The Manpower Component of the LEWISTON-AUBURN-LISBON ECONOMIC BASE STUDY will provide information to educational planners that will be useful in formulating local vocational education curricula. The component will compare local skill profiles with the skill proportions needed by industries that are likely to grow and to locate in the area (as identified in the Industrial Base Component of the study). The comparisons will make possible the identification of deficiencies that may exist between existing skills in the area and those that are needed by the industries identified in the Industrial Base Component. Educational planners will then be able to design specific programs to alleviate the deficiencies.

Enclosed is a copy of Technical Report #1, which describes the goals and techniques that will be included in the study; also enclosed is a copy of the latest progress report. If you would like further information about any aspect of the study, feel free to contact me any time at the Lewiston Planning Department.

Sincerely,

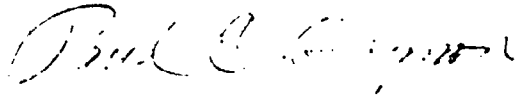

Paul E. Gagnon  
Assistant Planner

PEG/ms

Enclosures

June 20, 1972

Lewiston-Auburn Higher Education  
Facilities Project  
4 Court Street  
Auburn, Maine 04210

Dear Dr. Stinchcomb:

Thank you for giving me an opportunity to express some of the needs of Maine veterans which could be met by a community college in the Lewiston-Auburn area. I trust that the following comments will be helpful to you.

1. A community college can and would help returning servicemen, as many veterans desire education at higher levels. It is extremely difficult to do this due to the lack of facilities available and the high cost of maintaining a family while attending school. Although the VA provides educational assistance for a single veteran of \$175 a month, \$205 for a veteran and one dependent, \$230 for a veteran and two dependents, and \$13 a month for each additional dependent, this financial aid is not sufficient to cover the purchase of books, tuition, and related school costs. This hinders many veterans in taking advantage of upgrading and continuing their education in order to become more proficient and productive community citizens.

2. An estimated 967,000 veterans were in training under the current G.I. bill on June 1, 1972, the sixth anniversary of the bill. This is nearly fifteen percent more than a year ago and fifty-three percent more than two years ago. About 490,000 attend colleges or universities; 380,000 are in training below the college level. When final statistics are in for the fiscal year 1972, the number is expected to reach nearly two million. The number of veterans' wives, widows, and children included in the educational assistance program is estimated to be 24,000, which is an increase of seven percent.

3. At the recent job fair in this area, over 380 veterans received invitations, of which about 220 responded. Between thirty to thirty-five employers interviewed about fifty percent of the veterans. Approximately six or eight received jobs, about twenty-two others were referred to other existing job opportunities, and six were directed to apprenticeships. It was found that about twenty skills were in demand and should be developed in the area. It was also found that eighty percent or more needed additional education or training for the jobs for which they were hired, and at least

forty-six percent would need further training in order to qualify for job openings available. The Emergency Employment Act recently had from thirty-five to forty job openings in various fields, but much difficulty is being encountered in finding an equal number of veterans qualified to fill the openings without further training or education. Several hundred veterans are unemployed in this area.

4. Housing, school hours, and finances are all factors which hamper at least half of the veterans desiring to take advantage of educational training. Courses seen as helpful are programs in business administration, along with social service work, clerical, sales (all types) and bi-lingual courses (English-French); additional programs such as math, home economics, money management, financial counseling, basic English, and many others are both desired and needed where they could relate to vocational, as well as professional fields. There is a great need of college prep courses, prep courses for state and federal job examination, insurance, real estate, and securities, as well as basic public relations programs. The elementary grades need more directly related courses to everyday living, exposing its pitfalls and advantages, rather than too heavy an emphasis on the basic 3 R's. A community college, oriented to the needs of the people, employers, government, and civic groups in this area could well serve for the betterment of our entire society.

5. In the first half of 1972, there have been about 320 veteran inquiries from the greater Lewiston-Auburn area regarding educational benefits and thirty or more from areas within a fifty mile radius. This six month estimate could easily be doubled for a calendar year. An equal number could be estimated for on-the-job training and apprenticeships needed for prospective veterans. At least 1/3 of the above figure, or 250 veterans, who do not have benefits available would be interested in further education, either to upgrade jobs presently held or to qualify for better jobs. It is estimated that about 600 veterans are returning to this area annually. It would be desirable to have a community college which could provide programs needed by these veterans. It should be emphasized that instruction should be made available to part-time students by providing evening and Saturday classes.

These are statements of opinion based on knowledge and information available to me at the time regarding my present position as the Veterans Counselor for the tri-county area of Androscoggin, Franklin, and Oxford.

Sincerely yours,

F. W. DeFother

Veterans Counselor

600 State Street, Lewiston, Maine

Lewiston Adult Education Center  
68 Central Ave.  
Lewiston, Maine 04240  
Tel. 753-9131

U.S. GOVERNMENT  
PRINTING OFFICE

July 7, 1972

Dr. Larry Stinchcomb  
4 Court St.  
Auburn, Maine 04210

Dear Dr. Stinchcomb:

For the past two years as director of adult education in Lewiston, I have been concerned about and involved with a community college concept. Although nothing concrete has taken place through myself and other people of education oriented backgrounds, I have nonetheless continued to pursue the idea that this type of ideal should be continuously pursued until some success has been achieved.

I understand that you and your constituency are now pursuing a concept called the Lewiston Auburn Higher Education Facilities Project. I want you to know that I wholeheartedly support you and your endeavors and am available for consultation on whatever role I may best suit your needs. Your project is needed by thousands of citizens in the Lewiston Auburn area, and I urge you to pursue this with all your endeavors.

Sincerely,

*John L. Seymour*  
John L. Seymour, Director  
Adult Education

John L. Seymour

## **Lewiston-Auburn Community College Discussion in Relation to the CED of the University of Maine**

In a discussion with the Continuing Education Division (CED) Lewiston Office of the University of Maine Office it is found that 956 enrolled students are taking from 3 to 6 credit hours per week with the CED classes in Auburn. Many of these students are taking evening courses because of the need to work by day and many are also using these courses to work toward a degree, and commuting to Portland or Augusta for additional courses.

The establishment of a Community College would undoubtedly affect the enrollment, possibly diverting about a quarter of the students to a full time school (say 250 students). Four hundred students have been estimated to be available to the Lewiston-Auburn Community College from area schools on the basis of the first year only, so that the enrollment of the college in the second year could well be 1,000 students or more. The first year would produce 400 from the schools plus the 250 from the CED equalling 650 students. Considering that there would be a 15% dropout for second year from the 400 students, this would leave 340 second year students plus the 400 next first year students plus the continuing new and second year 250 students (diverted) equalling 990 students by this calculation.

In addition to these 990 students could well be additional students diverted by the continuing tightening economic conditions from taking their first two years of college at Orono, Augusta, Portland, or some place out-of-State. Although normally, students are anxious to leave home for college, financial conditions in the near future may well dictate that a sizable portion may have to stay home where adequate facilities are available.

As to the further effect on CED, it is felt that there would be no deleterious effect other than the above-mentioned diversion. In fact, the effect could be somewhat beneficial since CED would have a call on a reservoir of Lewiston-Auburn Community College professors and other personnel for its courses. This effect may not be felt at first, especially with the college operating afternoons and evening in available high school space but as the college gained its own buildings, it would gradually change to normal morning and afternoon classes with CED operating the evening for its normal night courses with college personnel and possible using college facilities.

The CED is doing a fine job in the Lewiston-Auburn area, but it cannot do the complete job that a properly equipped community college could offer. The Community College should be staffed and set up to offer a

two-year college course in several disciplines wither terminating with a diploma for that length of time or as the first two years of a continuing four year course to be continued elsewhere. CED cannot offer a similar course except to exceptional students who from evening courses and travel to Portland or Augusta for the remaining necessary classes. A complete two year higher educational offering is very necessary to the Lewiston-Auburn area and the Androscoggin Region. The CED can continue to offer some third and fourth year level courses for the benefit of those wishing them locally.

In addition, the value of the diploma or certificate would be greater from an established school than from the CED, even though the same professor might teach both classes in an educational manner. The weight of the institution and the established school is behind one but only the institution behind the other. Finally, no conflict is seen between the Central Maine Vocational Technical School and the proposed Community College. These institutions could cooperate in fields of mutual concern or of enriching the courses of the other, but they should remain separate and distinct units. The philosophy of education in each is geared to different products. In other than Liberal Arts, etc., the College is devoted in theory in the fields of engineering and sciences. The vocational institute is geared to the production technicians thoroughly familiar with the practical aspects and operations of particular phases of engineering and sciences. There is a vital need for both types of school. Without the college, the supply of engineers and scientists to develop new technologists would diminish, but without the vocational school the supply of quality designers and operators of the technologies would dry up.

Stuart A. Cunningham  
Tech Memo 02-046-10  
June 1, 1970

**A Quick Survey of the Need for a Community College  
For the Lewiston-Auburn Area**

**Object:**

To make a first assessment on the need for a Community College in the Lewiston-Auburn Area.

**Introduction:**

There has been placed before this Commission the prospect of establishing a Community College and a request for some basic information relative to the demand and need. As a result, discussions in person, but mostly by telephone and mail, have been had with numerous sources, including the Lewiston, Auburn and many other high school principals, student councilors (or both), Continuing Education Division of University of Maine, Lewiston; Bliss College, Lewiston; Auburn Maine School of Commerce, Auburn, etc. The following comments up to the point at which the statistical discussion begins is merely placed here as background material in order to clothe this report in some form of reference. It is felt that these comments from various sources are too diverse to be properly identified at this time to have any official weight, but merely indicate the trends of thinking of these individuals. (It is quite conceivable that the final product, if it comes to pass, would bear any resemblance to these generalizations).

**Generalized Plan of Procedure:**

It is apparently generally hoped to start a community college in the twin city area within the near future, possibly using available high school space for a beginning and later, as the school develops, obtain a campus and buildings. Generalized discussions in Auburn and Lewiston indicate that the high school space in Auburn would not be available until 4:00 p.m. or preferably after 7:00 p.m., upon approval of the Board of Education, similar space could be available in Lewiston at the high school or at a junior high school at times ranging from 2:30 p.m. on, according to the needs of the school.



### **Courses Desired:**

First, the normal Arts and Sciences courses might be a base. Along with this, there is apparently a demand for Business courses and an associated Business Education course. Other apparently necessary courses are Engineering (introductory, or pre-engineering) in the fields of Civil, Electrical and possibly Chemical.

### **Years of Study to be Offered:**

This school is considered to be a two year college, offering both terminal courses and courses to be continued at an established four year college. Whether or not the future would see this school as a four year college is not within this scope of speculation.

### **Needs That have been Stated:**

1. For proper development of the second largest population accumulation in Maine, a community college is said to be a need to provide the proper local education.
2. Industry is now demanding skills and training on the college level not now available locally. This is true both of present local industry and of potential industry. The lack of such a college is a factor in the lack of attraction of higher-type industry.
3. The community college is a means of further education by which many local young people might attend college, but who otherwise would be shut off from any further education.
4. Students show a marked reluctance to C.E.D. classes in which they sit with teachers making up compulsory courses.

### **Some Arguments against the School:**

1. With the University of Maine available in Portland and in Augusta, a duplication of facilities could be established.
2. The Continuing Education Division of the University of Maine and Central Maine Vocational Technical Institute are offering all the courses needed locally.
3. The twin cities are a manufacturing community and could not afford the luxury of a community college.

### **Statistical Work Done by the A.V.R.P.C.:**

Here we leave the realm of conjecture and enter into the work done in the Commission. The Staff of the Commission questioned the school systems of the Region for the following information:

1. **Graduating Class size**
2. **Number going to work**
3. **Number going into Armed Services**
4. **Number going on to higher or more education**
  - (a) **by type of school**
  - (b) **by specific schools, locations**
5. **Number estimated that would want to attend college but cannot**
6. **Estimate of number that would attend a community college**

The first four questions were readily answered for the most part, but few answers were forthcoming from the last two, mainly because of lack of information. However, a special inquiry produced the information discussed at the end of this paper.

## ANSWERS TO QUESTIONNAIRE

Table 1

High School & Location	1970 Class size	Work	Service	More School	TYPE OF SCHOOL						
					4 years	College 2 years	Nursing	Voc.	Bus.	Prep.	Others
Lewiston High School	484	246		217	149	13	16	15	23	1	0
Auburn											
Edward Little High School	475	194	36	245	162	43	6	14	22	7	
Lisbon High School	105	40	5	60	36	4	1	7	5		7
Norway											
Oxford Hills High School	225			100	40	3		10	7		40
Buckfield High School	39			27	17			3	2		2
Turner											
Leavitt Area High School	74			40	15		3	11	4		7
Gray High School					11	1		4			
Farmington High School	206			111	44			15	15		
Mexico High School	120			57	27	3	3	6	14	1	3
Bethel High School				45	22	6	1	1	2		13
<b>TOTALS</b>	<b>1,728</b>	<b>480</b>	<b>41</b>	<b>902</b>	<b>523</b>	<b>73</b>	<b>30</b>	<b>86</b>	<b>94</b>	<b>9</b>	<b>72</b>

These were the schools called up to the point at which this work was terminated. Further calls were to be scheduled but were not made.

Table 1 shows the answers to the questions.

## Diversions:

The establishment of a Community College would result in a diversion of students from other colleges to a local community college, on the four year, two year and business college levels.

This diversion would be considered greatest in the core area adjacent to the college and diminish according to the distance.

Therefore, as a first approximation, it was felt that a full half of the local graduating class seeking higher education in these categories, would be attracted to a local school and that a diminishing percentage by distance would be applied. Therefore, in Table 2, these diversions are listed and the total number is estimated.

### DIVERSIONS TO A COMMUNITY COLLEGE

Table 2

Place	Percent Diversion	4 Year College	2 Year College	Business School	Total
Lewiston	50%	75	6	11	92
Auburn	50%	81	21	7	109
Lisbon	50%	18	2	2	22
Oxford Hills	37.5%	15	1	3	19
Buckfield	37.5%	6		1	7
Turner	37.5%	6		2	8
Gray	30%	3			3
Farmington	30%	13		5	18
Mexico	30%	7	1	1	9
Bethel	30%	6	2	1	9
<b>TOTAL</b>					<b>296</b>

From this total of 296 students we will then add a percentage to cover the areas not previously studied completely.

### FACTORED SCHOOL AREAS

**Table 3**

<b>Town</b>	<b>Base Town</b>	<b>Base Total</b>	<b>Estimated Students</b>
Dixfield	Mexico	9	5
Livermore Falls	Farmington	18	6
Bridgton-Casco	Oxford Hills	19	6
Fryeburg	Oxford Hills	19	3
Anson	Farmington	18	4
Rumford	Mexico	9	20
Rangely	Mexico	9	2
Monmouth	Oxford Hills	19	6
<b>TOTAL</b>			<b>52</b>

Therefore, with the 296 calculated, the total becomes 348. Now, as with any new facility, an induced traffic factor of 10% is added, or 35 new students for a final total of 383 students.

The Continuing Education Division of the University of Maine has a very active program in the twin city area with an enrollment of about 950 students. One quarter of these might be expected to be diverted, or about 250 students.

The final total of students available to the Community College will then be 383 students for each of two years, less 10% drop out for the second year (728 students) plus 250 students covering the two year spread, making a total of 978 students in a continuing two year college.

Considerations of this diversion based on many considerations including quality instruction to standard college classes and the continuing economic setback that will require more students to study from homes rather than from a dormitory.

## ADDENDUM

### Prospective Students for a Community College

The main point determined in the following section is that although 229 students will consider this college acceptable in relation to other schools, the important fact is that 132 students not now college bound who might never have the opportunity to obtain further education will be provided the opportunity to do so.

These totals will be seemingly in conflict with some presented in Table 2, but are based upon newer information.

The Lewiston High School Student Adviser is in the process of making such a study, but as an interim estimation, it was figured that of the 484 graduating students and 14 post graduation students of 1970, since roughly 32% were accepted in four and two year colleges, 20% would be an acceptable diversion to a Community College. This percentage would work out to 100 students. Of the remaining 68% of the students (or 339 students) 20% of these would be presumed to wish further education otherwise denied because of a variety of factors. This factors to 67 with a total possible community college enrollment from Lewiston of 167 students.

(Taking this further and assuming a 15% drop-out for the second year, the total two-year enrollment from Lewiston might be  $167 + 142 = 309$  students).

The Auburn High School Student Adviser did not wish to make a generalized statement such as this, but in a discussion, of the 164 students who went to higher education last year and the 194 students who were considered as entering the labor force, it was agreed that some of each would undoubtedly be candidates for the community college, and that all of the 42 students who went on to Junior College would be candidates for the community college. This discussion shows a basic estimation of 42 students to which would be added (on the basis of Lewiston's estimate) 103 students diverted from other colleges and 53 students from those entering the labor force making a total of 156.

(Again, taking this further and assuming a 15% second year drop-out, there should be  $106 + 132$  or 288 students in the two years from Auburn).

In discussion with the Lisbon High School Student Adviser, similar results were obtained, considering the relative size of the school. Lisbon could send 12 students diverted from other colleges and 7 students who otherwise would not attend college.

(For a two year total as above, 19 · 16 or 35 students would be the two year contribution).

Lastly, in order to test a high school outside the metropolitan area, the Oxford Hills High School, Norway, Student Advisor was called. It was figured that as an estimate, 14 students would be diverted to a community college from other colleges and 5 would go where that group now has no opportunity to attend college.

(For a two year total as above, 16 · 9 or 35 students would be the two year contribution).

As a recapitulation,

#### PROSPECTIVE STUDENTS FOR A COMMUNITY COLLEGE

Table 4

High School	College Bound	Not College Bound	Total
Lewiston	100	67	167
Auburn	103	53	156
Lisbon	12	7	19
Oxford Hills	14	5	19
TOTAL	229	132	361

## **OXFORD HILLS HIGH SCHOOL**

**Class of 1971**

**June 14, 1971**

Of the 193 students who will graduate on June 17, 1971, 102 students or 52.8% of the class plan to attend institutions of higher learning. The breakdown of those continuing their education is as follows:

<b>4 year programs</b>	<b>64 students for 33.2%</b>
<b>2 year programs</b>	<b>28 students for 14.5%</b>
<b>Other programs of varying lengths</b>	<b>10 students for 5.2%</b>

Of the 91 students who have no immediate plans for continuing their education, the breakdown is as follows:

**52 or 26.9% plan to enter the field of full-time employment.**

**16 or 8.3% plan to enter the Armed Forces during graduation.**

**4 or 2.1% plan marriage.**

**19 or 9.8% are uncertain of their future plans at this time.**

Members of the Class of '71 plan to attend the following institutions of higher education:

<b>Austrian College</b>	<b>1</b>
<b>Bernard's School of Beauty Culture</b>	<b>1</b>
<b>Bob Jones University</b>	<b>1</b>
<b>Bowdoin College</b>	<b>1</b>
<b>Bryant Stratton College</b>	<b>1</b>
<b>Career Academy</b>	<b>1</b>
<b>Central Maine Vocational Technical Institute</b>	<b>5</b>
<b>Colby College</b>	<b>1</b>
<b>Eisenhower College</b>	<b>1</b>
<b>Graham Junior College</b>	<b>1</b>
<b>Hartford Airline School</b>	<b>1</b>
<b>Hartford School of Accounting</b>	<b>1</b>
<b>Kennebec Valley Vocational Technical Institute</b>	<b>2</b>
<b>Lowell Tech</b>	<b>1</b>
<b>Maine Central Institute</b>	<b>1</b>
<b>Middlebury College</b>	<b>1</b>
<b>Newbury School of Beauty</b>	<b>1</b>
<b>Northern Maine Vocational Technical Institute</b>	<b>2</b>
<b>Peter Bent Brigham Hospital</b>	<b>1</b>



Plus Gray School of Business	1
Ricker College	1
St. Joseph's College	1
St. Mary's School of Radiologic Technology	1
Southern Maine Vocational Technical Institute	2
Thomas College	2
Unity College	2
Universal Airline School	1
University of Maine at Bangor	4
University of Moine at Farmington	9
University of Maine at Machias	1
University of Maine at Orono	30
University of Maine at Portland-Gorham	9
University of Miami	1
University of Utah	1
University of Vermont	1
Washington Bible College	1
Weaver Airline School	1
Wentworth Institute	1
Wheelock College	1
William & Mary College	1
Wisconsin State University	1

**LAKE REGION HIGH SCHOOL**

**Naples, Maine**

**1972 Graduating Class**

<b>Total Graduates</b>		<b>113</b>
To 4 year college	4	
To 2 year college	2	
To vo - tech.	21	
To nursina school	1	
	—	<b>48</b>
To military service	6	
Many others already have jobs.		

# APPENDIX E



**BEST COPY AVAILABLE**

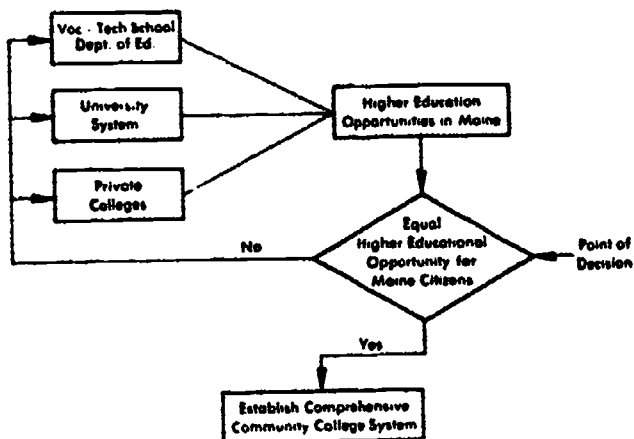

**UNIVERSITY OF CALIF.  
LOS ANGELES**

**LA 14 1975**

**CLEARINGHOUSE FOR  
JUNIOR COLLEGE  
INFORMATION**